

Intermot Hydraulic Motors
IAM+ Series

TECHNICAL CATALOGUE

INDEX

MOTOR TECHNICAL DATA	Pag. 3
GENERAL INFORMATION	Pag. 5
IAM+ H1 SERIES	Pag. 9
IAM+ H2 SERIES	Pag. 19
IAM+ H3 SERIES	Pag. 30
IAM+ H4 SERIES	Pag. 40
IAM+ H5 SERIES	Pag. 49
IAM+ H6 SERIES	Pag. 59
IAM+ H7 SERIES	Pag. 67
FLOW DISTRIBUTORS	Pag. 76
ACCESSORIES	Pag. 78

From November the 1st 2011, INTERMOT ITALY introduces the new IAM+ series. Even if this new generation is externally completely similar to the previous one, it can be easily distinguished by our logo  which is placed on oil conducts.



More important are the internally applied variations, which are related to the choice of new materials, heat treatments, new tolerances, and special seals. All these innovations enable to transfer 20% power more and longer lifetime. Moreover noise was reduced. Thanks to these improvements most of which are realized in co-operation with the Users, we are allowed to expand the use of our motors in many applications which were not approachable from the previous range.

Motor Technical Data

MODEL	N° of pistons	Displacement	Specific Torque	Pressure			Speed		Max Power		Dry Mass	Max case pressure	Max back pressure	Temperature range	Minimum speed	Inertia moment of rotating parts
				Max Cont.	Max Int.	Peak	Max Cont.	Peak	hp	kW						
				cm ³ /rev	Nm/bar	bar			rpm							
IAM+ H1	100	99	1.6	300	350	400	950	1050	64	48	26	6	70	- 30 + +70	2 ÷ 3	18
	150	159	2.5	300	350	400	950	1050	64	48						
	175	175	2.8	300	350	400	950	1050	64	48						
	200	207	3.3	300	350	400	750	850	64	48						
	250	251	4.0	300	350	400	750	850	64	48						
	300	299	4.8	300	350	400	750	850	64	48						
IAM+ H2	200	198	3.1	300	350	400	800	900	79	59	42	6	70	- 30 + +70	2	27
	250	255	4.1	300	350	400	750	850	79	59						
	300	304	4.8	300	350	400	750	850	79	59						
	350	362	5.8	300	350	400	650	750	79	59						
	400	425	6.8	300	350	400	600	700	79	59						
	500	493	7.8	300	350	400	500	600	79	59						
	600	565	9.0	300	350	400	500	600	79	59						
IAM+ H3	400	404	6.4	300	350	400	600	680	110	82	68	6	70	- 30 + +70	1	214
	500	491	7.8	300	350	400	600	680	110	82						
	600	616	9.8	300	350	400	550	630	110	82						
	700	707	11.3	300	350	400	450	500	110	82						
	800	779	12.4	300	350	400	400	450	110	82						
IAM+ H4	800	764	12.2	300	350	400	450	530	129	96	92	6	70	- 30 + +70	1	267
	900	877	14.0	300	350	400	450	530	129	96						
	1000	966	15.4	300	350	400	300	400	129	96						
	1100	1093	17.4	300	350	400	300	400	129	96						
	1200	1193	19.0	300	350	400	300	350	129	96						
	1300	1333	21.2	300	30	400	230	280	129	96						
	1400	1406	22.4	300	350	400	230	280	129	96						

The data specified into this catalogue are for product description purpose only and must not be interpreted as warranted characteristic in legal sense. Intermot reserves the right to implement modification without notice. 3

MODEL	N° of pistons	Displacement	Specific Torque	Pressure			Speed		Max Power		Dry Mass	Max case pressure	Max back pressure	Temperature range	Minimum speed	Inertia moment of rotating parts	
				Max Cont.	Max Int.	Peak	Max Cont.	Peak	hp	kW							kg
				cm ³ /rev	Nm/bar	bar			rpm								bar
IAM+ H5	1200	1232	19.6	300	350	400	300	350	193	144	173	6	70	- 30 + +70	0.5	697	
	1400	1376	21.9	300	350	400	300	350	193	144	173						
	1600	1690	26.9	300	350	400	300	340	193	144	173						
	1800	1816	28.9	300	350	400	250	300	193	144	173						
	2000	2127	33.9	300	350	400	230	260	193	144	173						
	2200	2221	35.3	300	350	400	220	240	193	144	173						
IAM+ H6	2200	2207	35.1	300	350	400	220	260	286	213	308	6	70	- 30 + +70	0.5	1745	
	2500	2526	40.2	300	350	400	220	260	286	213	308						
	2800	2808	44.7	300	350	400	220	260	286	213	308						
	3000	2985	47.5	300	350	400	210	250	286	213	308						
	3200	3290	52.4	300	350	400	200	240	286	213	308						
	3500	3481	55.4	300	350	400	200	240	286	213	308						
IAM+ H7	3900	3909	62.2	300	350	400	160	200	290	216	405	6	70	- 30 + +70	0.5	4064	
	4300	4345	69.2	300	350	400	150	190	290	216	405						
	4600	4618	73.5	300	350	400	140	190	290	216	405						
	5000	5092	81.0	300	350	400	140	180	290	216	405						
	5400	5387	85.7	300	350	400	130	170	290	216	405						

General Information

Hydraulic fluids

For the choice of hydraulic fluid, Intermot recommend the use of high quality mineral -based hydraulic oil, containing anti-wear, anti-foaming, anti-oxidation and extreme pressure additives.

Allowable oil temperature range:- 20 to +80°C

Operating viscosity range: optimal from 40 cSt 60cSt

Choice of hydraulic oil should be made so that the viscosity is within the given range at its normal operating temperature.

Filtration

Intermot recommend the use of 25 µm filter (until 10 µm for closed circuits applications).

Clean oil and therefore efficient filters are essential for the correct functioning of all the components in the hydraulic system. The efficiency of the filters is impaired by the gradual accumulation of particles intercepted and filters should be regularly inspected. Special attention is required when the hydraulic system is first put into operation or when any of the components are replaced or have become worn through use. The efficiency of a filter may be measured, for example, verifying the pressure drop across the filter. Follow filter manufacturer's recommendations for its lifetimes, its cleaning and substitution.

Drain line position

The drain line must be positioned in such a way that there will always be a sufficient amount of oil in motor casing so that bearings and all dynamic part will be lubricated.

If the motor is installed with the shaft in a horizontal position, the drain line must be connected to the upper drain hole.

If the motor is installed with the shaft pointing upwards, motor casing must be entirely filled of oil, drain line must be connected in such a way to avoid air can enter, in order to prevent output shaft bearing to run dry.

Start-up

Before connecting any tubes ensure that they are thoroughly clean. Avoid any oxidation of surface that come into contact with oil. Before starting work, motor casing must be filled in with oil. Before starting work, the hydraulic circuit should be purged of air. This can be achieved by running the motor without load for 10-20 minutes, checking no leakage there be from connections. During the first few hours of working under load checks should be made for leakages from connection and ensure all components remain firmly fixed to their supports. All motors are factory tested and do not require to be run-in.

Fluidi idraulici

Si raccomanda di usare olio idraulico di alta qualità a base minerale, con additivi antiusura, anti schiuma, anticorrosione e per elevate pressioni.

Gamma di temperature accettabile - 20 to +80 °C

Gamma di viscosità di lavoro: ottimale da 40 cSt a 60 cSt.

La scelta dell'olio idraulico deve essere effettuata in maniera che la viscosità sia entro la gamma consentita alla normale temperatura di lavoro.

Filtri

Si consigliano filtri da 25 µm o più fini (fino a 10 µm per applicazioni in circuito chiuso).

Per un corretto funzionamento di tutti i componenti nel sistema idraulico è molto importante che l'olio sia incontaminato, e che quindi sia garantita la completa efficienza degli elementi filtranti. Questa si riduce per il progressivo accumulo di particelle, quindi i filtri vanno regolarmente controllati. Si consiglia di dedicare speciale attenzione alla prima messa in funzione del sistema idraulico o nel caso di sostituzione di un qualsiasi componente per rottura od usura. Il controllo dell'efficienza del filtro è possibile, ad esempio, con la verifica della caduta di pressione attraverso il filtro. Si consiglia quindi di seguire le norme del fabbricante del filtro per quanto concerne durata, pulizia e sostituzione dello stesso.

Posizionamento del tubo di drenaggio

La linea di drenaggio deve essere posizionata in modo che ci sia sempre in carcassa olio sufficiente a lubrificare i cuscinetti e tutti dinamici del motore.

Se il motore è installato con l'albero orizzontale, la linea di drenaggio deve essere collegata al foro di drenaggio superiore.

Se il motore è installato con l'albero verso l'alto, il corpo motore deve essere interamente riempito con olio prima della installazione, la linea di drenaggio deve essere collegata in modo che non entri aria, per evitare che il cuscinetto lato uscita lavori a secco.

Messa in funzione

Prima del collegamento dei tubi assicurarsi che questi siano rigorosamente puliti. Evitare qualsiasi ossidazione delle superfici che verranno a contatto con l'olio. Prima di iniziare il lavoro, la carcassa del motore deve essere riempita di olio. Prima di iniziare il lavoro va eliminata l'aria dal circuito idraulico. Questo si effettua mandando in velocità il motore a bassa pressione per 10-20 minuti, controllando che non vi siano perdite dai collegamenti. Durante le prime ore di lavoro sotto sforzo si consiglia di ricontrollare se ci sono perdite e di assicurarsi che tutti i componenti rimangano fissati ai loro supporti. Tutti i motori sono collaudati e non necessitano di un periodo di rodaggio.

Direction of shaft rotation

All motors are bidirectional. The direction of shaft rotation is determined by the direction of oil flow. Standard motors are supplied so that flow entering from port A causes the shaft to rotate clockwise (as seen from motor shaft side). Flow entering from port B causes anticlockwise rotation (as seen from motor shaft side).

Senso di rotazione dell'albero

Tutti i motori sono bidirezionali. Il senso di rotazione è determinato dalla direzione del flusso. Per i motori standard, con il flusso in entrata dal port A del distributore l'albero gira in sensi orari (visto dal lato albero). Con il flusso in entrata dal porto B, l'albero gira in senso antiorario (visto dal lato albero).

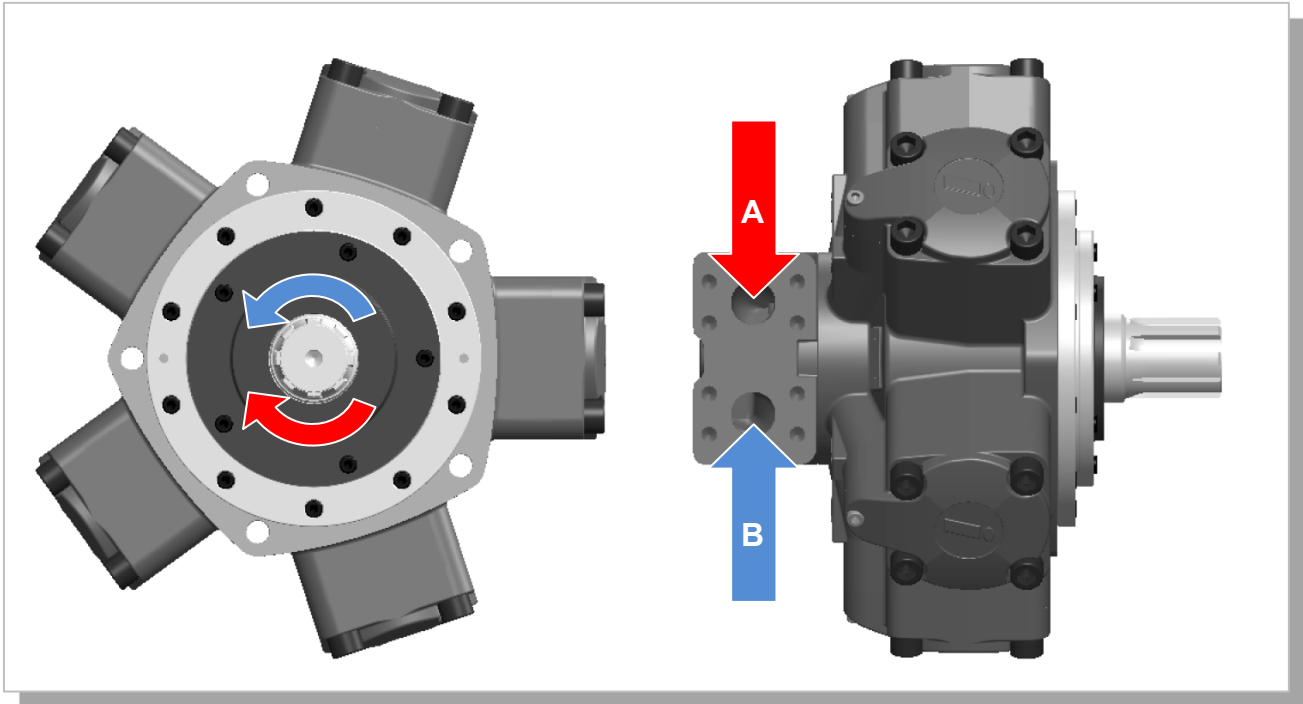

Flushing flow

Cooling flow is necessary to assure the minimum oil viscosity. The following table shows the flushing flow approximate values that are suggested for IAM+ motors. In all the cases, the flushing flow must be adequate to assure the minimum oil viscosity: therefore the flushing flow will depend by the motor displacement, working conditions and oil type and must be set making some oil drain temperature.

Flussaggio

Per assicurare la minima viscosità di oli consentita è necessario un flusso di raffreddamento. La seguente tabella riporta il flussaggio approssimato suggeriti per i motori IAM+. In tutti i casi, il flussaggio deve essere adeguato per assicurare la minima viscosità dell'oli.; quindi il flussaggio dipende dalla cilindrata, dalle condizioni di lavoro e dal tipo di oli, e deve essere monitorando la temperatura dell'olio di drenaggio.

Motor	Flushing flow [l/min]
IAM+ H1 100	5
IAM+ H1 150 – 175 – 200 – 250 – 300	6
IAM+ H2 200 – 250 – 300	
IAM+ H2 350 – 400 – 500	8
IAM+ H3 400 - 500	
IAM+ H2 600	
IAM+ H3 600 – 700 – 800	10
IAM+ H4 800 – 900 – 1000 – 1100 – 1200 – 1400	
IAM+ H5 1000 – 1200 – 1400 – 1600 – 1800 – 2000	
IAM+ H5 2200	15
IAM+ H6 2500 – 2800 – 3000 – 3200 – 3500	
IAM+ H7 3900 – 2800 – 4300 – 4600 – 5000 – 5400	20

Flushing in performance diagrams

Each performance diagram shows working condition where flushing is suggested (area numbered from 4 to 6 in each performance diagram).

Area 1: Continuous operation.

Area 2: Intermittent operation for period 3-5 minutes every 10-15 minutes.

Area 3: Intermittent operation for very short period (3-5 seconds every 10-15 minutes).

Area 4: Continuous operation with flushing.

Area 5: Intermittent operation for period 3-5 minutes every 10-15 minutes with flushing.

Area 6: Intermittent operation for very short period (3-5 seconds every 10-15 minutes) with flushing.

High volumetric efficiency motors

On radial piston hydraulic motors with high volumetric efficiency, and therefore Intermot IAM+ series, there can be a phenomenon of oil overheating in motor body.

Oil coming from piston and distributor goes into motor body. When this oil quantity is very scanty, it means there is a good volumetric efficiency. In some cases this is positive because high volumetric efficiency avoids motor rotation even under external stress. In other cases, this high efficiency can cause problems on the motor because oil exchange is missing.

In fixed application, for example, where the motor is running constantly for 8 or more hours a day high volumetric efficiency can create a temperature increasing in motor body. In this case temperature increasing is to be avoided with the use of flushing.

Flushing consists of carrying fresh oil (taken from the hydraulic circuit) in motor body. Oil is usually taken from return line to avoid any loss of efficiency.

In this way, all internal parts of the motor are protected with this lubrication and cooled with fresh oil, so that total efficiency is optimized.

Flussaggio nei diagrammi delle performance

In ogni diagramma delle performance sono mostrate le condizioni di lavoro e il flussaggio (aree nominate da 4 a 6).

Area 1: Operazioni in continuo.

Area 2: Operazioni intermittenti per un periodo di 3-5 minuti ogni 10-15 minuti.

Area 3: Operazioni intermittenti per un periodo breve (3-5 secondi ogni 10-15 minuti)

Area 4: Operazioni in continuo con flussaggio.

Area 5: Operazioni intermittenti per un periodo di 3-5 minuti ogni 10-15 minuti con flussaggio.

Area 6: Operazioni intermittenti per un periodo breve (3-5 secondi ogni 10-15 minuti) con flussaggio.

Motori ad alto rendimento idraulico

Nei motori idraulici a pistoni radiali ad alto rendimento volumetrico, come i motori Intermot della serie IAM+, può esserci un problema di surriscaldamento dell'olio nel corpo motore.

L'olio proveniente dal pistone e dal distributore va in circolo nella carcassa. Quando tale quantità di olio è molto bassa c'è un alto rendimento volumetrico. In taluni casi questo è positivo poiché l'alto rendimento volumetrico evita la rotazione del motore anche sotto sforzo esterno. In altri casi, un rendimento volumetrico alto può causare problemi al motore poiché manca il ricircolo di olio all'interno.

In applicazioni fisse, per esempio, dove il motore lavora costantemente per 8 o più ore al giorno, un alto rendimento volumetrico può creare un aumento di temperatura nel corpo motore. In tal caso l'aumento di temperatura può essere evitato attraverso il flussaggio.

Il flussaggio consiste nell'apportare olio fresco (preso dal circuito idraulico) all'interno della carcassa. L'olio è generalmente preso dalla linea di ritorno onde evitare problemi di perdita di efficienza.

In tal modo, tutte le parti interne sono protette da tale lubrificazione e raffreddate con olio fresco quindi il rendimento totale viene ottimizzato.

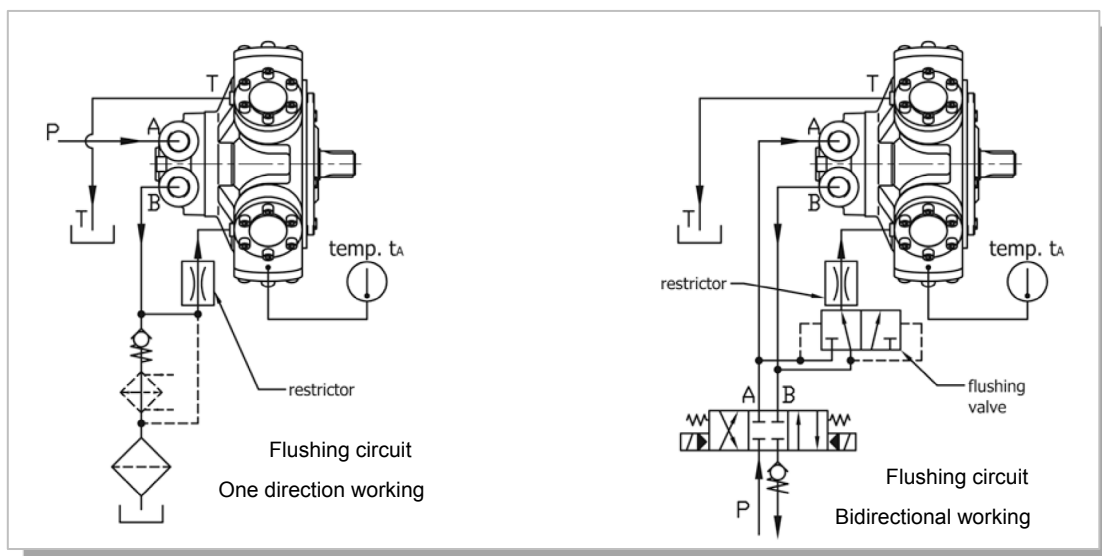

Side load charts

The side load charts printed in this catalogue allow to calculate the lifetime of the motor when at a given distance from mounting face it's experienced a given radial load. At the header of any graph motor series and pressure drop expressed in bar can be read.

As an example suppose you want to evaluate lifetime of an hydraulic motor IAM+ H1 at the following condition:

- Pressure drop $\Delta p = 300$ bar
- speed at output shaft 450 rpm
- side load of 10 kN at 50 mm mounting face

Diagrammi di carico radiale

I diagrammi di carico radiale riportati in questo catalogo permettono di calcolare la vita del motore quando ad una assegnata distanza dal piano di flangiatura viene applicato un carico radiale. Nell'intestazione in alto di ogni diagramma è riportato il tipo di motore a cui si riferisce e la pressione in bar per la quale è valevole.

Si supponga per esempio di volere una stima della vita di un motore IAM+ H1 alle seguenti condizioni:

- salto di pressione elaborato $\Delta p = 300$ bar
- velocità in uscita 450 rpm
- carico radiale di 10 kN a 50 mm dal piano di flangiatura

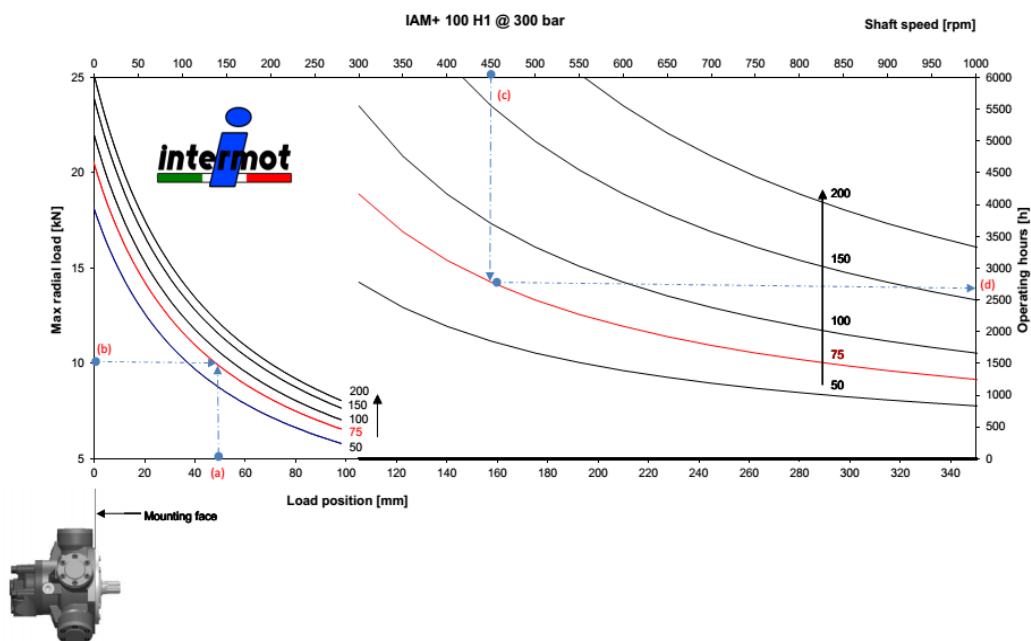

For the calculation follow dotted lines as below mentioned.

- 1) From left hand side chart:
 - Sketch an horizontal line from (a) side load;
 - Sketch a vertical line from (b) position of side load from mounting face.

These horizontal and vertical lines meet at the red highlighted curve named 75 (millions of revolutions).

- 2) From right hand side chart:
 - Sketch a vertical line from (c), shaft output speed, till meeting the red highlighted curve 75;
 - Find on vertical right hand side axis the predicted lifetime.

Per il calcolo seguire le linee tratteggiate come segue indicato nel seguito.

- 1) Dal diagramma di destra:
 - Tracciare una retta orizzontale passante per (a) – carico radiale;
 - Tracciare una retta verticale passante per (b) – posizione del carico rispetto al piano di flangiatura.

L'orizzontale per b e la verticale per a si incontrano sulla curva evidenziata denominata 75 (milioni di rivoluzione).

- 2) Dal diagramma di sinistra:
 - Tracciare una verticale per (c) – velocità in uscita dell'albero motore – fino alla curva 75 evidenziata in rosso;
 - Proseguire in direzione orizzontale fino in (d) sull'asse verticale più a destra dove è possibile leggere le ore di vita stimate.

Intermot Hydraulic Motors IAM+ Series

H1 Models

IAM+ 100 – 150 – 175 H1

IAM+ 200 – 250 – 300 H1

INDEX

TECHNICAL DATA	Pag. 10
IAM+ 100 - 150 - 175 H1	Pag. 11
IAM+ 200 - 250 - 300 H1	Pag. 12
GRAPHIC PERFORMANCES	Pag. 13
ORDERING INSTRUCTIONS	Pag. 18

IAM+ H1

Technical data

MODEL		N° of pistons	Displacement	Specific Torque	Pressure			Speed		Max Power		Dry Mass	Max case pressure	Max back pressure	Temperature range	Minimum speed	Inertia moment of rotating parts
					Max Cont.	Max Int.	Peak	Max Cont.	Peak								
					cm ³ /rev	Nm/bar	bar										
IAM+ H1	100	5	99	1.6	300	350	400	950	1050	64	48	26	6	70	-30 ÷ +70	2 ÷ 3	18
	150		159	2.5	300	350	400	950	1050	64	48						
	175		175	2.8	300	350	400	950	1050	64	48						
	200		207	3.3	300	350	400	750	850	64	48						
	250		251	4.0	300	350	400	750	850	64	48						
	300		299	4.8	300	350	400	750	850	64	48						

IAM+ H1

Dimensional drawings

IAM+ 100 – 150 – 175 H1

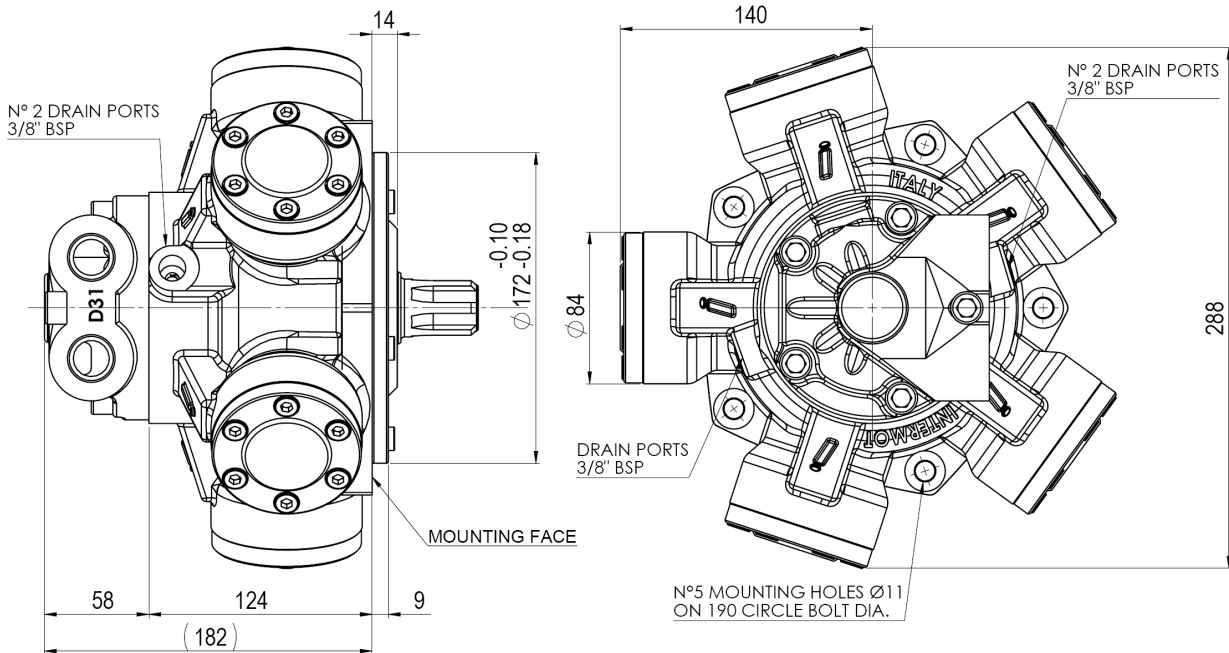

SHAFTS

A0: Standard splined shaft

A1: Splined shaft on request

A2: Parallel shaft on request

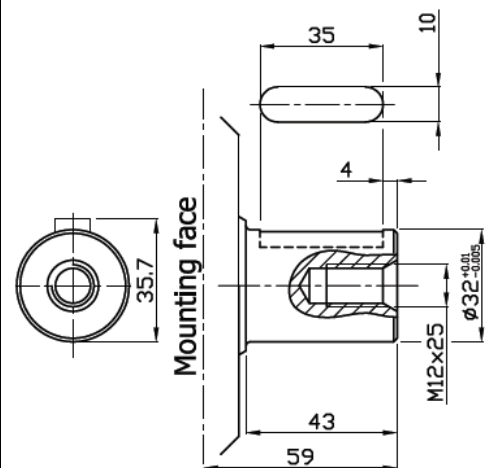
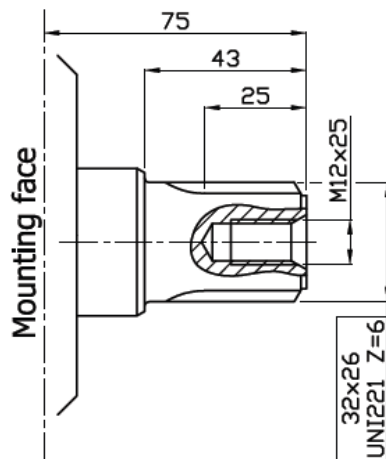
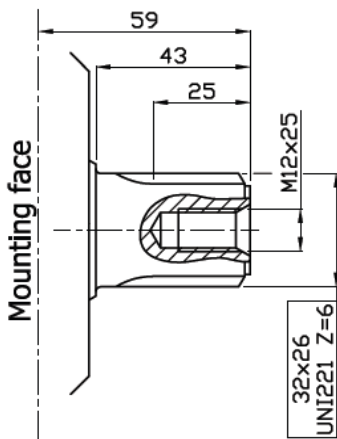

IAM+ H1

Dimensional drawings

IAM+ 200 – 250 – 300 H1

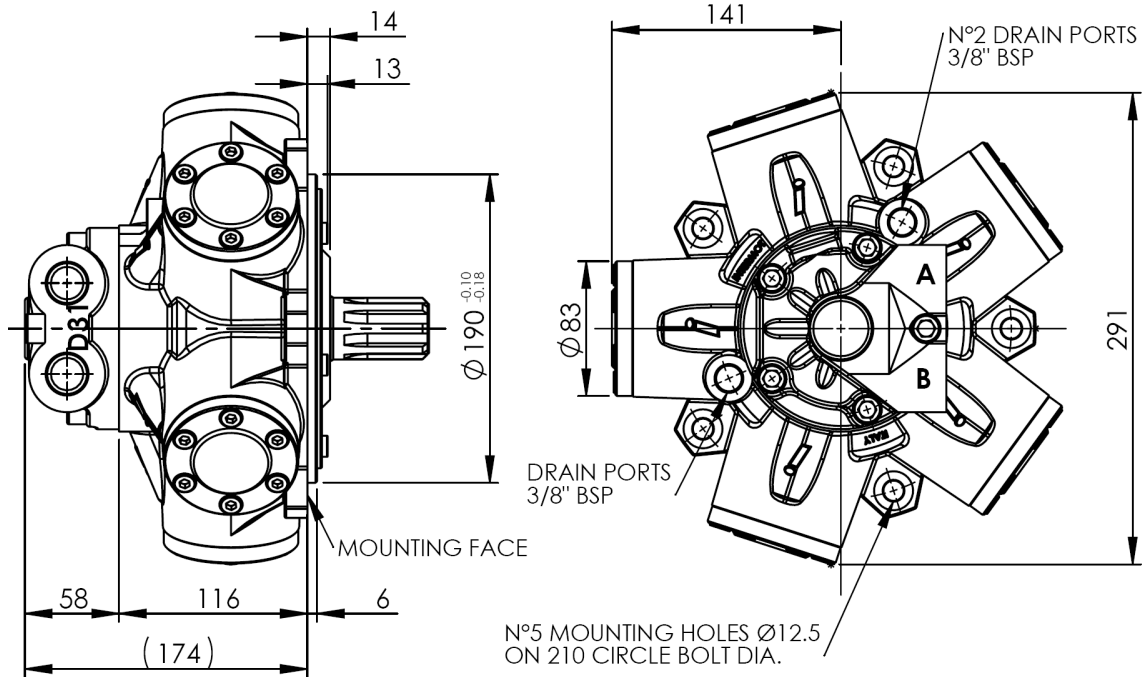

SHAFTS

A0: Standard splined shaft

A2: Parallel shaft on request

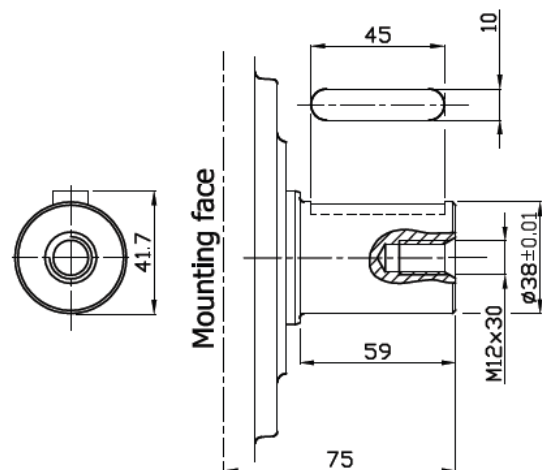
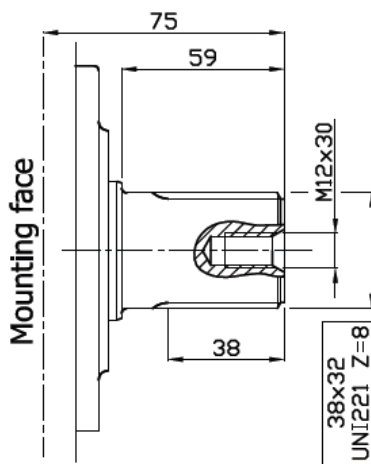

IAM+ H1

Power charts

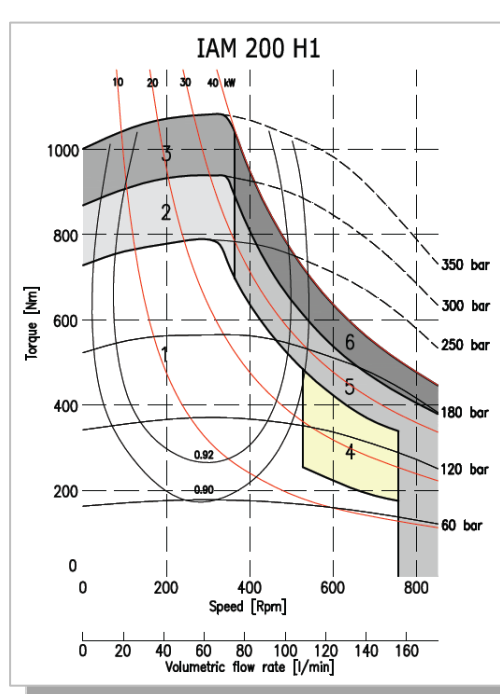
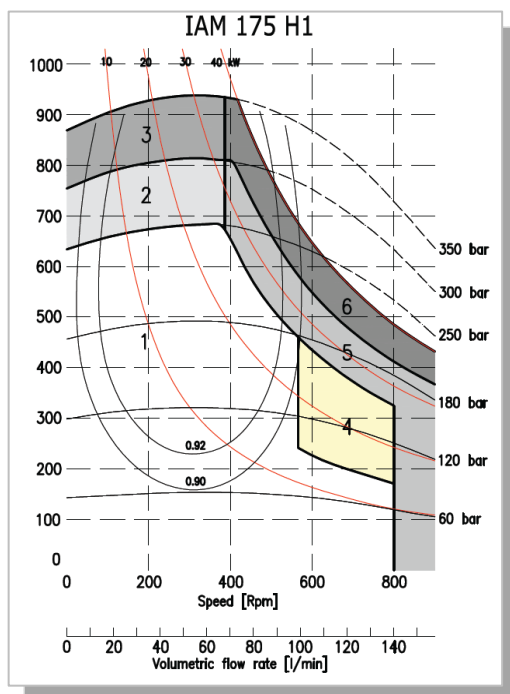
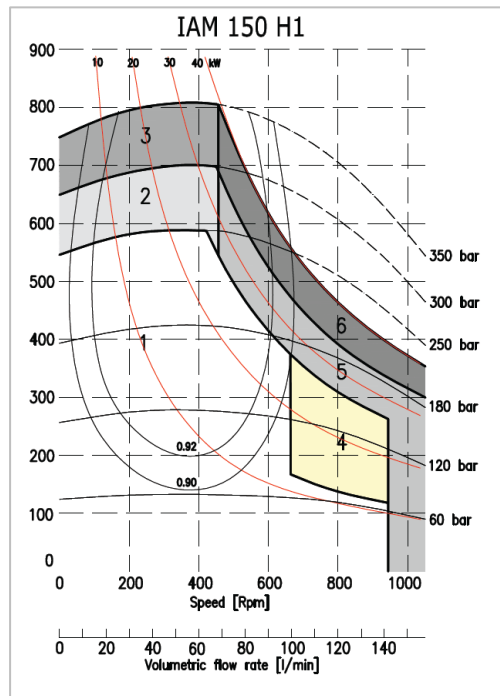
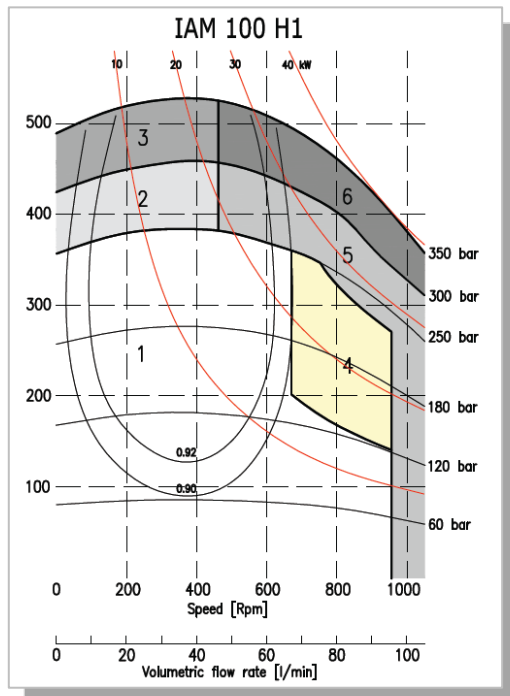

IAM+ H1

Power charts

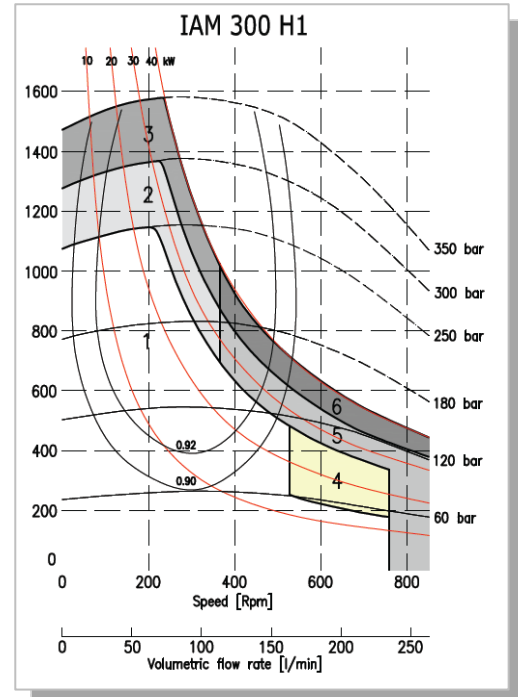
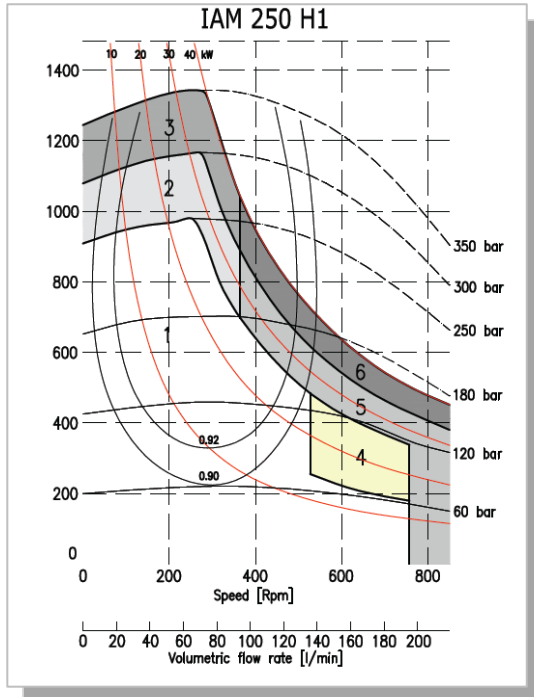

1	Continuous operation	4	Continuous operation with flushing
2	Intermittent operation for period 3-5 minutes every 10-15 minutes	5	Intermittent operation for period 3-5 minutes every 10-15 minutes with flushing
3	Intermittent operation for very short period (3-5 seconds every 10-15 minutes)	6	Intermittent operation for very short period (3-5 seconds every 10-15 minutes) with flushing

IAM+ H1

Side load charts

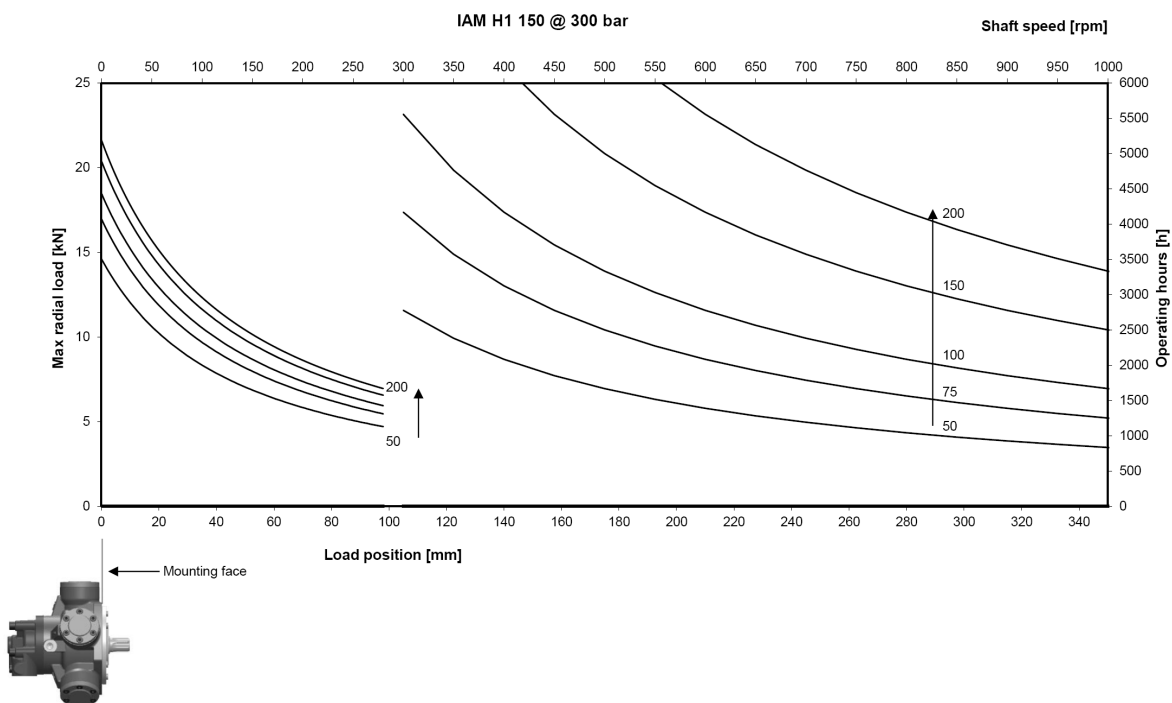
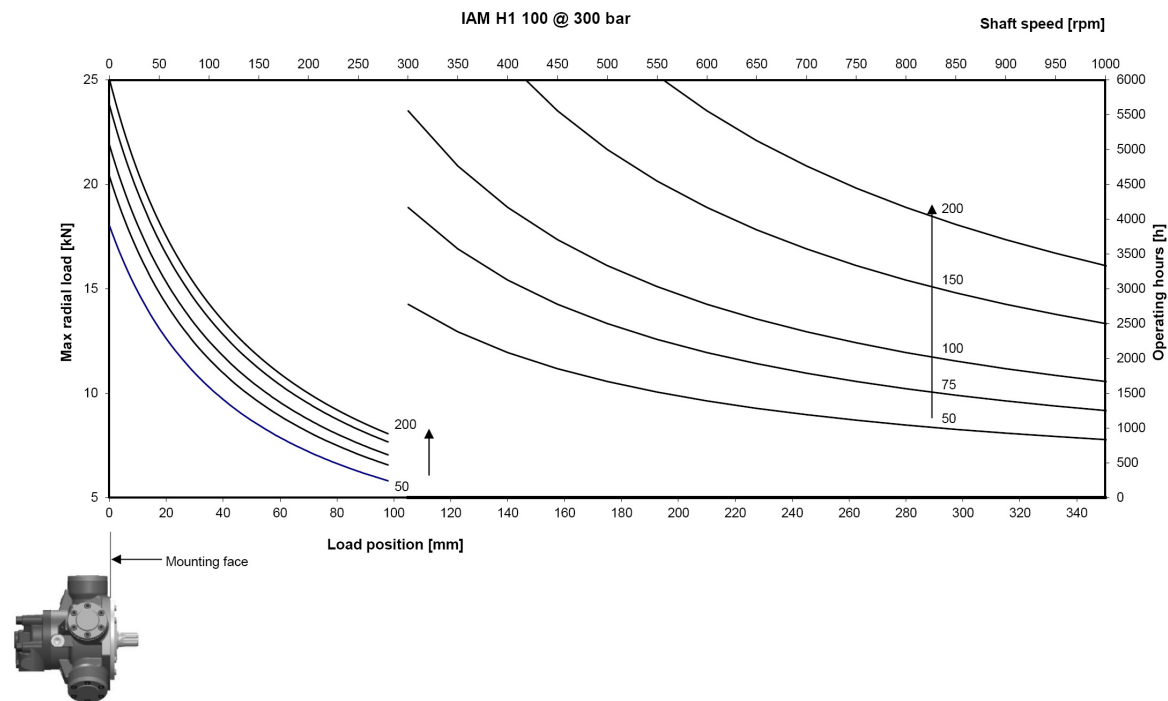

IAM+ H1

Side load charts

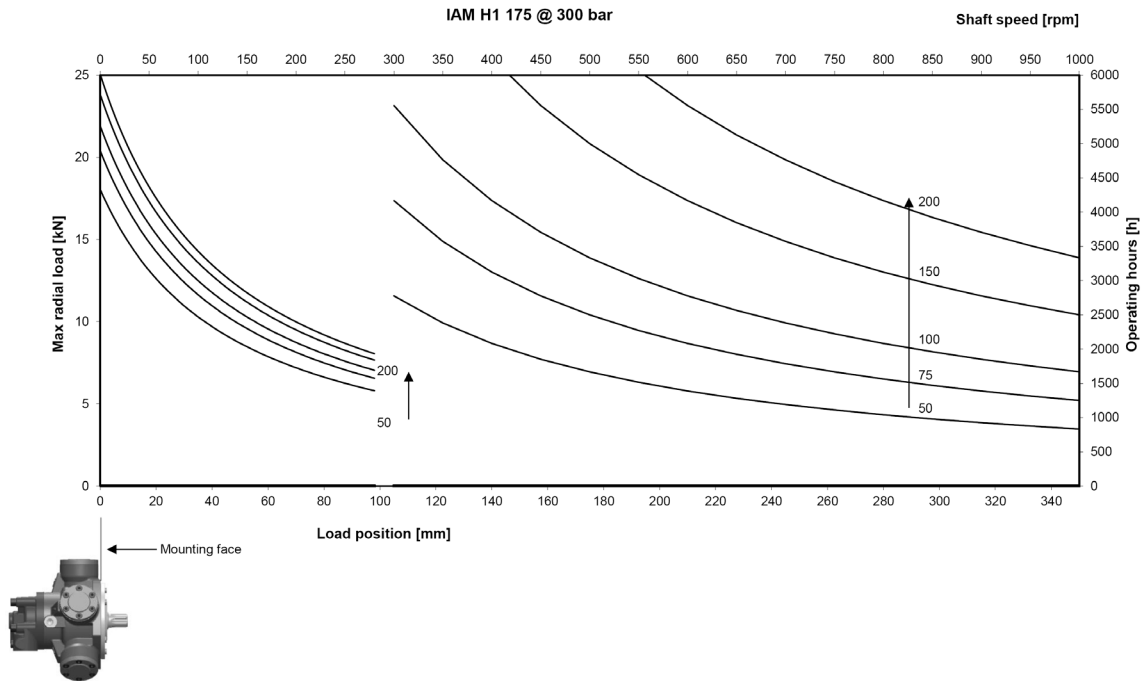

IAM+ H1

Side load charts

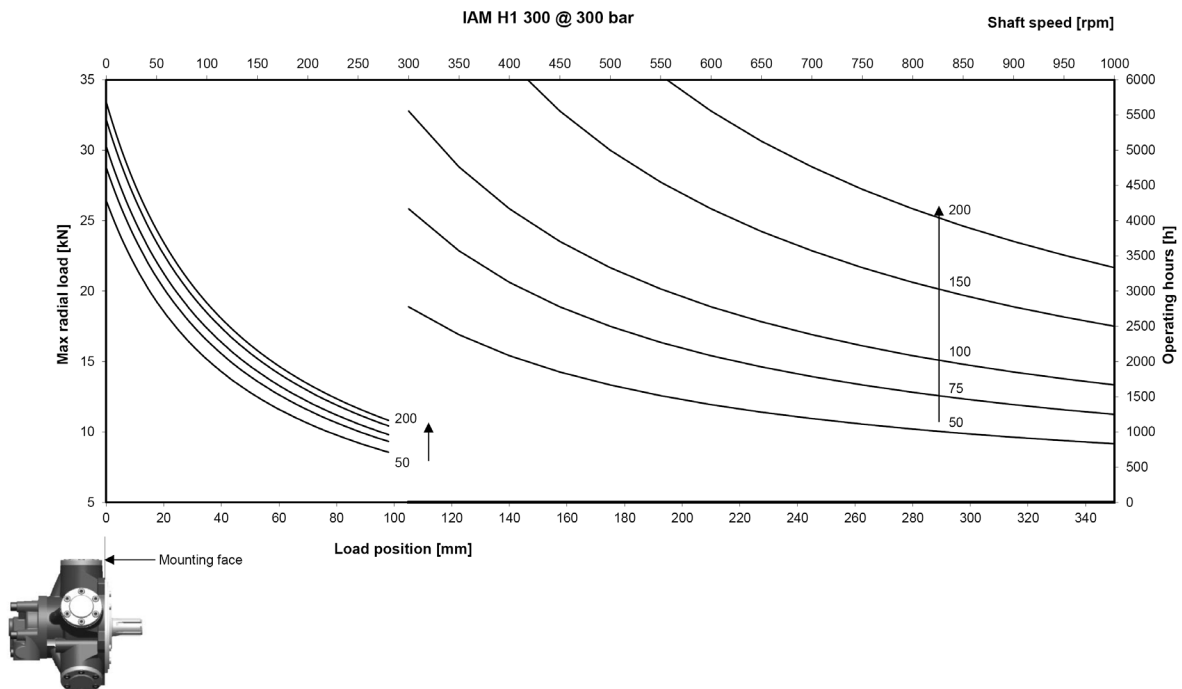
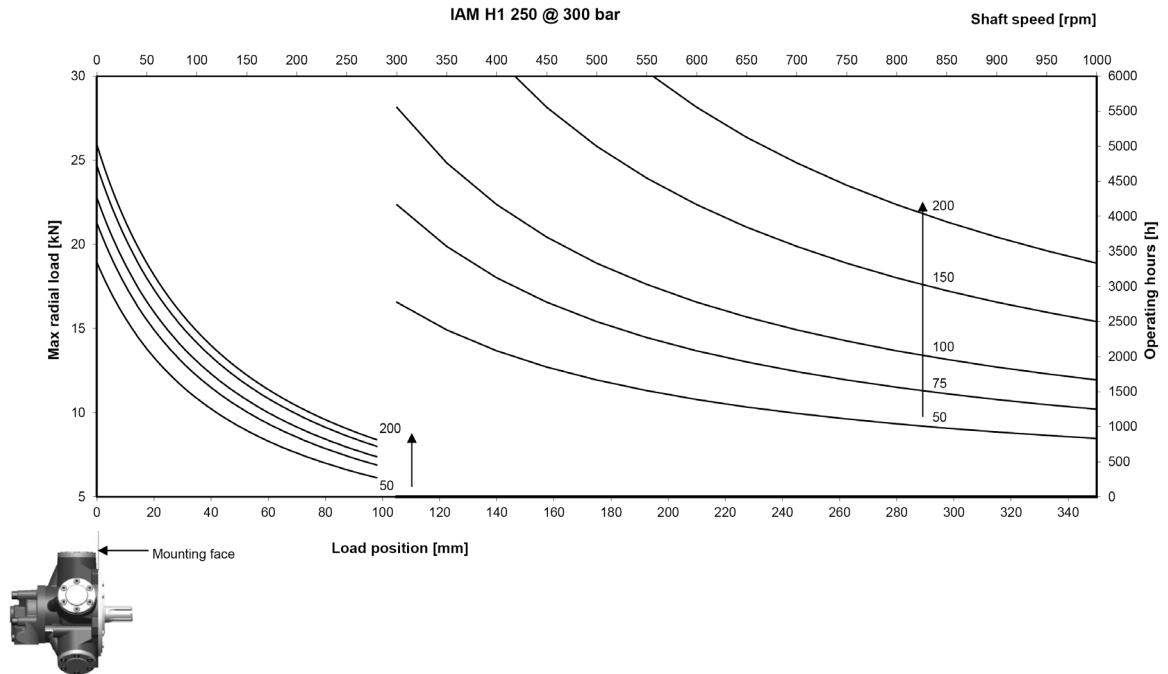

IAM+ H1

Ordering instructions

IAM+	---	H1	A _	D __	--	SB _
Model						
Displacement						
100 cc/rev						
150 cc/rev						
175 cc/rev						
200 cc/rev						
250 cc/rev						
300 cc/rev						
Housing						
H1						
Shaft						
A0 – Standard splined shaft						
A1 – Special splined shaft						
A2 – Parallel keyed shaft						
Distributor						
D31 – ¾" BSP						
D310 – 1" BSP						
D40 – 1" BSP						
D47 – SAE 1" 3000 psi flange						
Tachometer						
K						
TA						
TB						
EST						
Spline billet						
SB1 – 26 UNI 221						
SB2 – 32 UNI 221						

EXAMPLE : IAM+ 200 H1 A0 D31

IAM+ 100 H1 A0 D31 K SB1

Intermot Hydraulic Motors
IAM+ Series

H2 Models

IAM+ 200 – 250 – 300 – 350 H2
IAM+ 400 – 500 – 600 H2

INDEX

TECHNICAL DATA	Pag. 20
IAM+ 200 - 250 – 300 - 350 H2	Pag. 21
IAM+ 400 - 500 - 600 H2	Pag. 22
GRAPHIC PERFORMANCES	Pag. 23
ORDERING INSTRUCTIONS	Pag. 29

MODEL	N° of pistons	Displacement	Specific Torque	Pressure			Speed		Max Power		Dry Mass	Max case pressure	Max back pressure	Temperature range	Minimum speed	Inertia moment of rotating parts
				Max Cont.	Max Int.	Peak	Max Cont.	Peak	hp	kW						
		cm ³ /rev	Nm/bar	bar			rpm		kg	bar	bar	°C	rpm	kg cm ²		
IAM+ H2	200	198	3.1	300	350	400	800	900	79	59	42	6	70	- 30 ÷ +70	2	27
	250	255	4.1	300	350	400	750	850	79	59						
	300	304	4.8	300	350	400	750	850	79	59						
	350	362	5.8	300	350	400	650	750	79	59						
	400	425	6.8	300	350	400	600	700	79	59						
	500	493	7.8	300	350	400	500	600	79	59						
	600	565	9.0	300	350	400	500	600	79	59						

IAM+ 200 – 250 – 300 – 350 H2

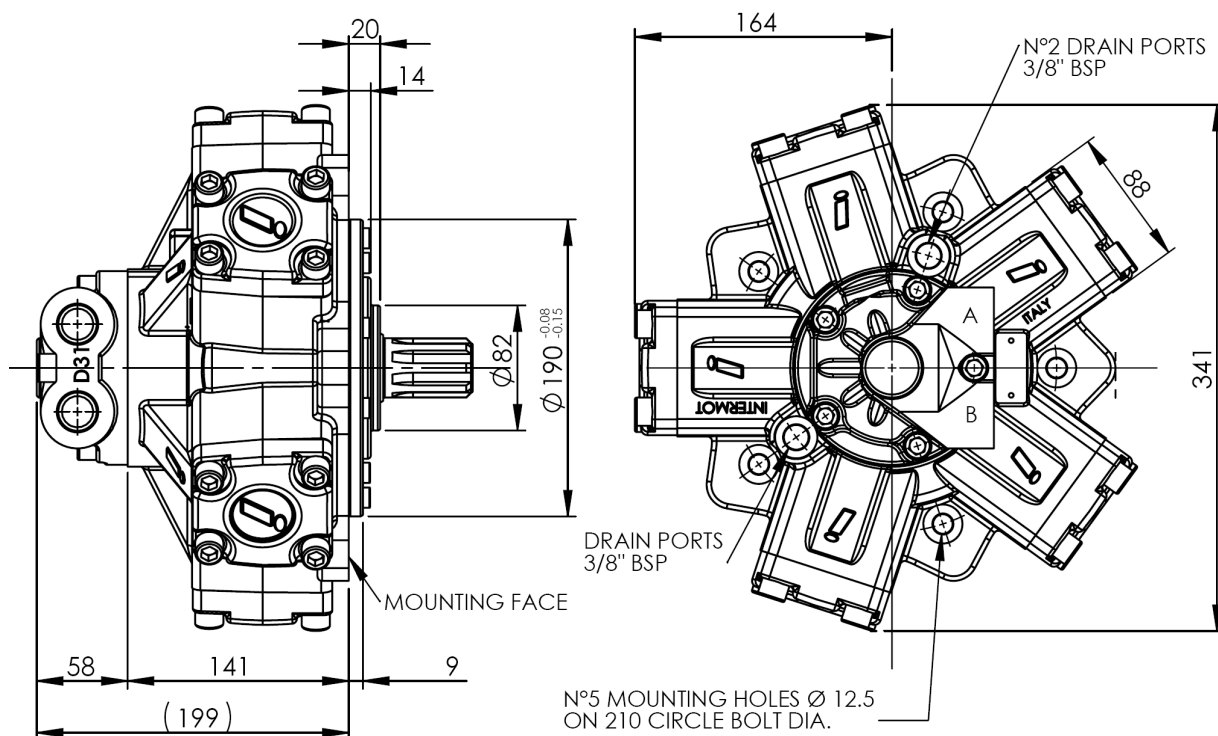

SHAFTS

A0: Standard splined shaft

A2: Parallel shaft on request

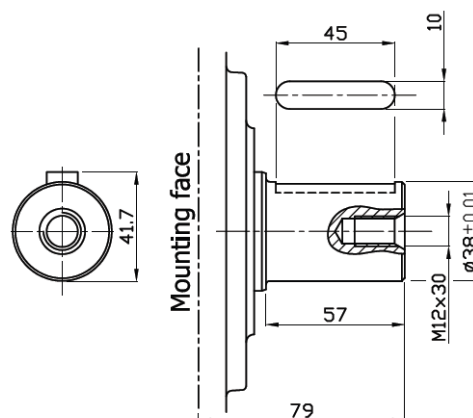
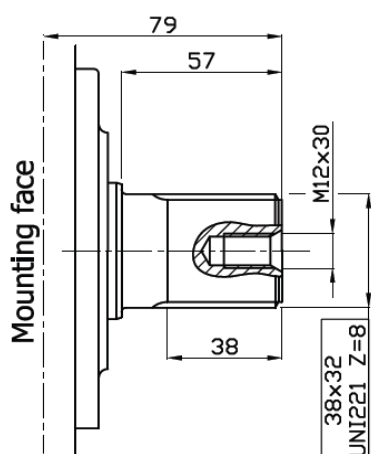

IAM+ H2

Dimensional drawings

IAM+ 400 – 500 – 600 H2

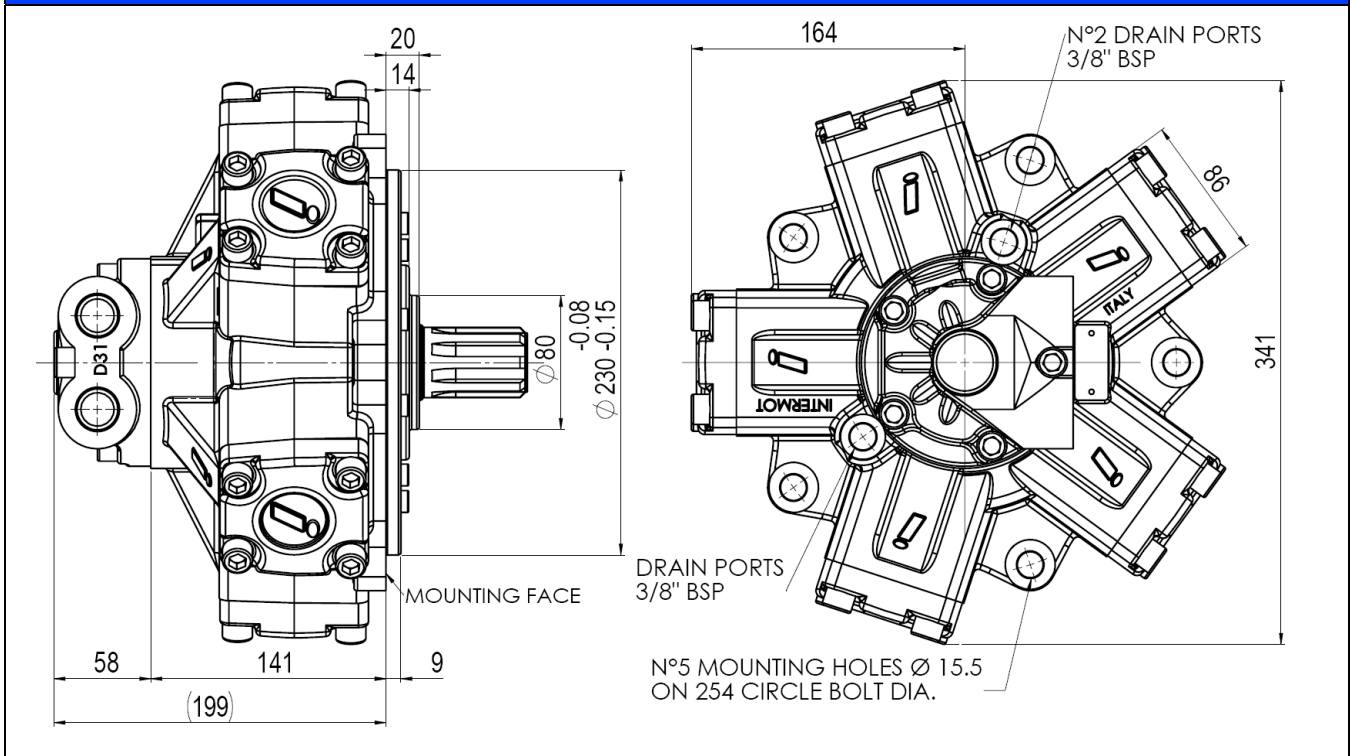

SHAFTS

A0: Standard splined shaft

A2: Parallel shaft on request

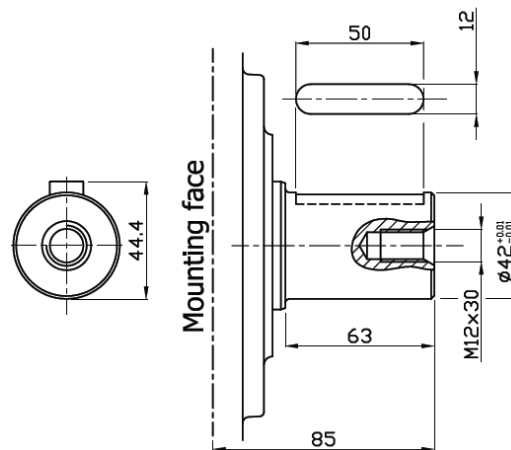
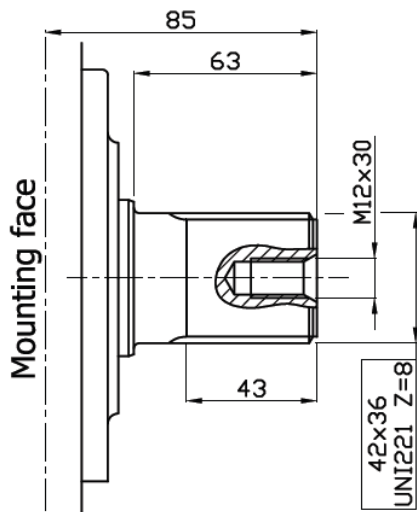

IAM+ H2

Power charts

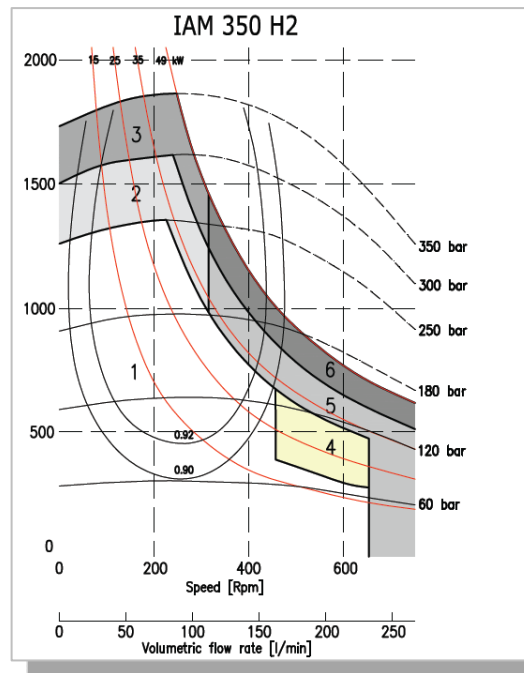
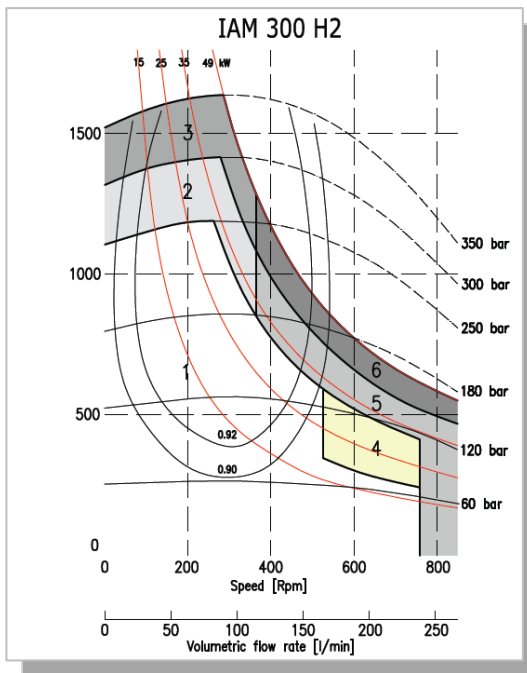
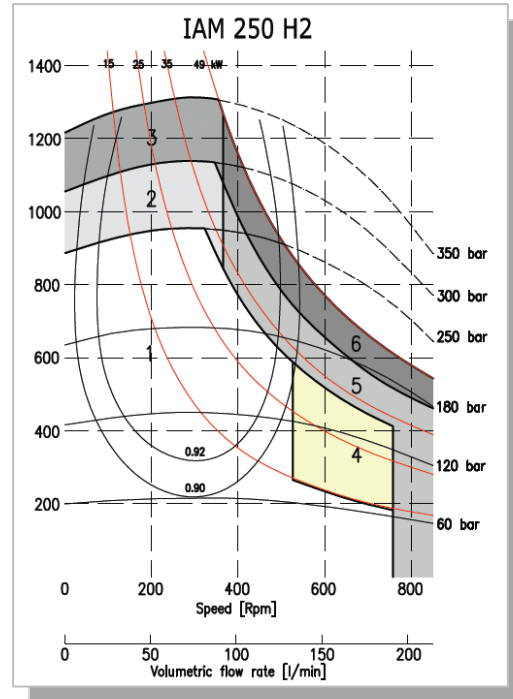
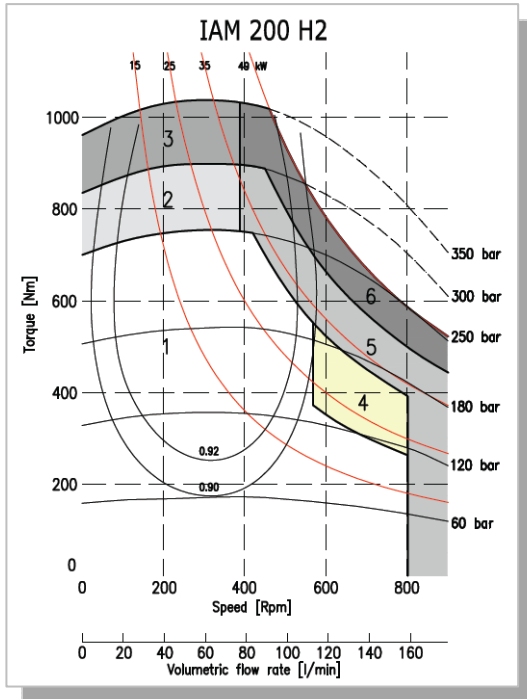

IAM+ H2

Power charts

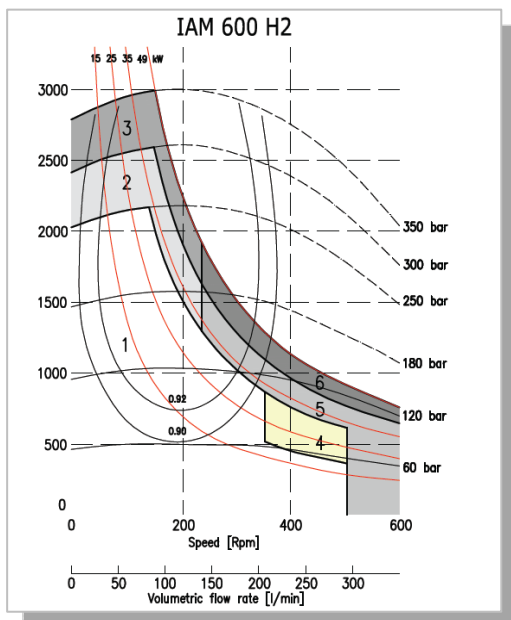
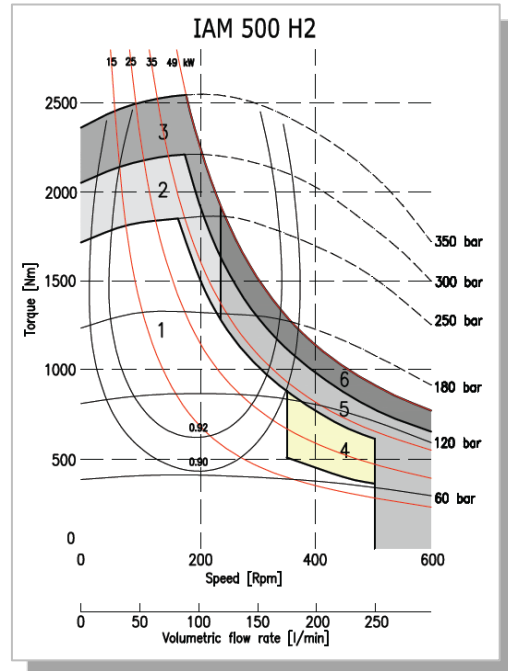
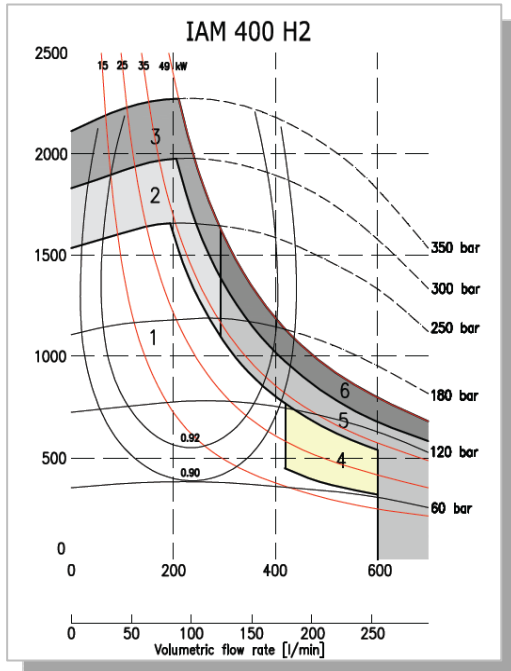

1	Continuous operation
2	Intermittent operation for period 3-5 minutes every 10-15 minutes
3	Intermittent operation for very short period (3-5 seconds every 10-15 minutes)
4	Continuous operation with flushing
5	Intermittent operation for period 3-5 minutes every 10-15 minutes with flushing
6	Intermittent operation for very short period (3-5 seconds every 10-15 minutes) with flushing

IAM+ H2

Side load charts

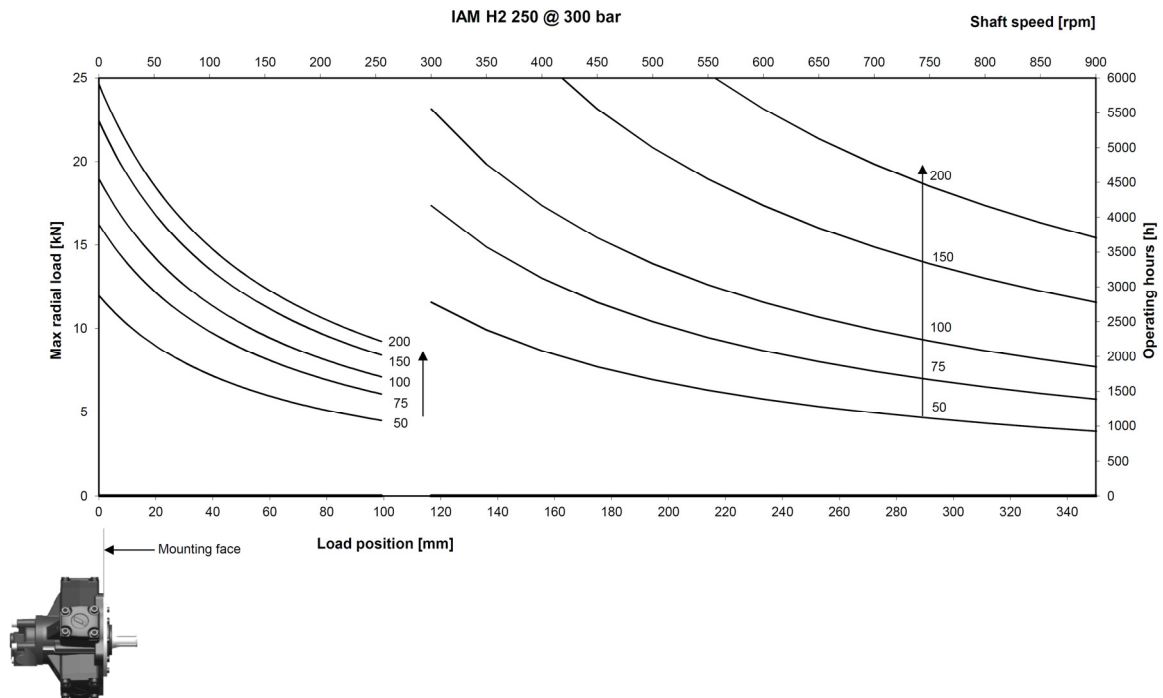
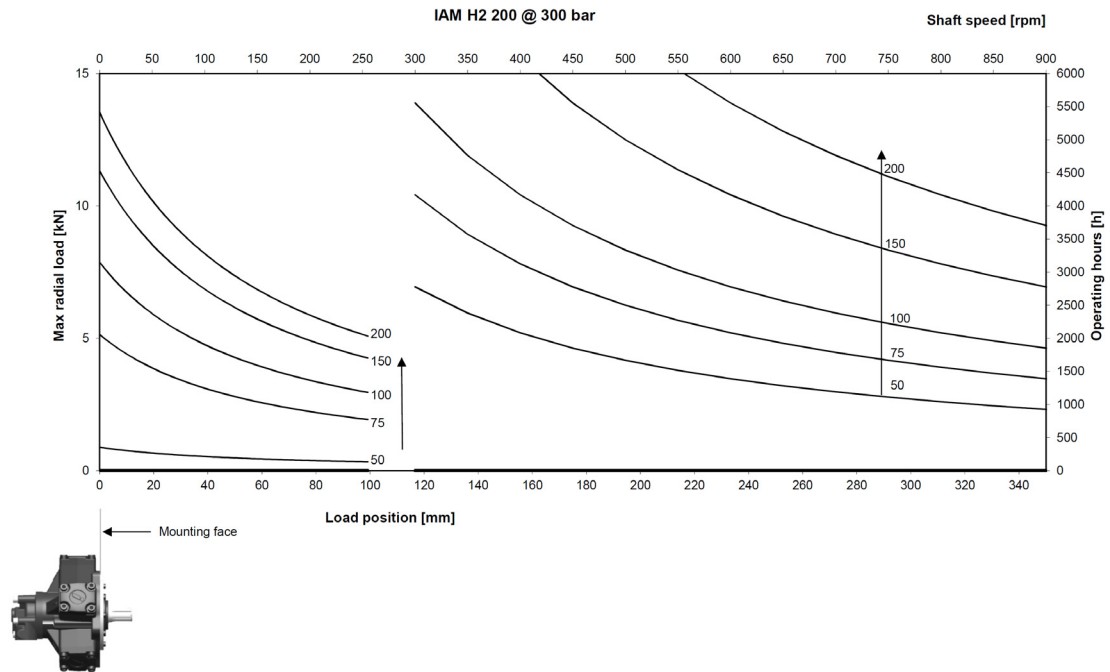

IAM+ H2

Side load charts

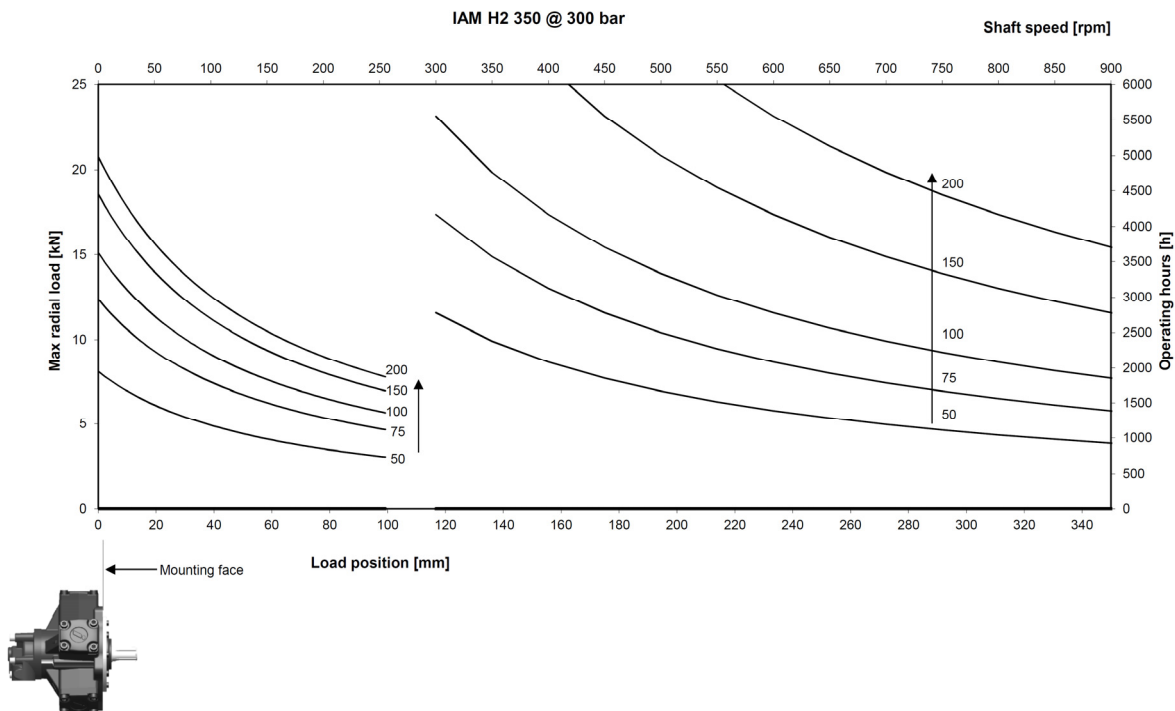
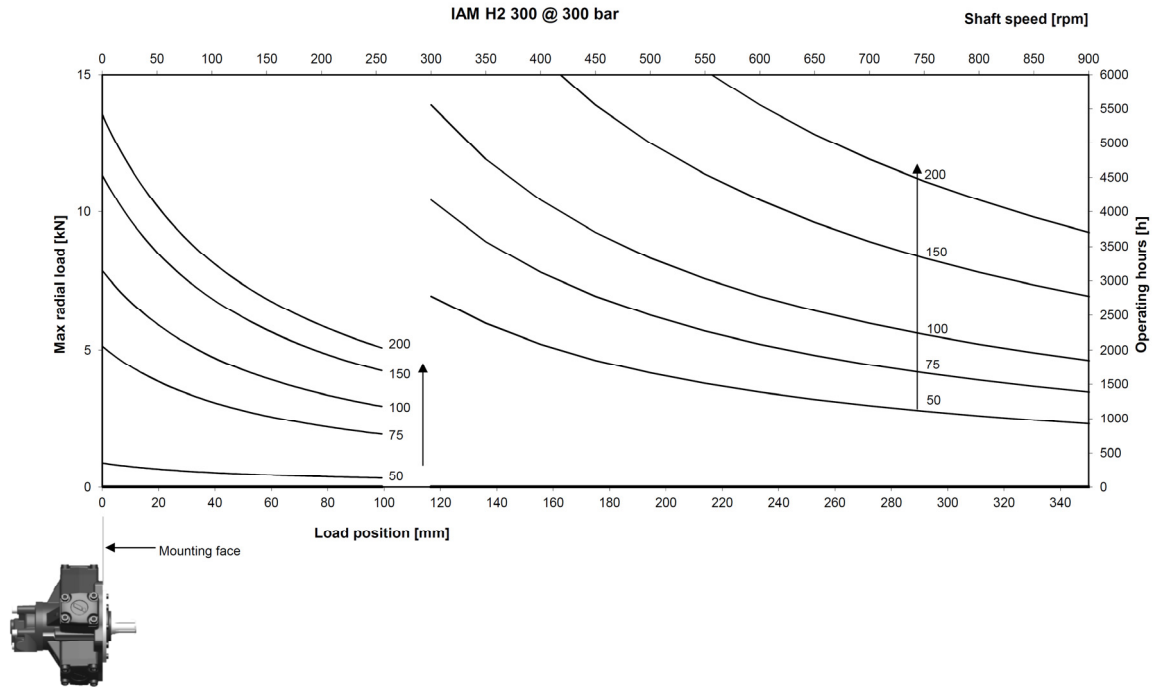

IAM+ H2

Side load charts

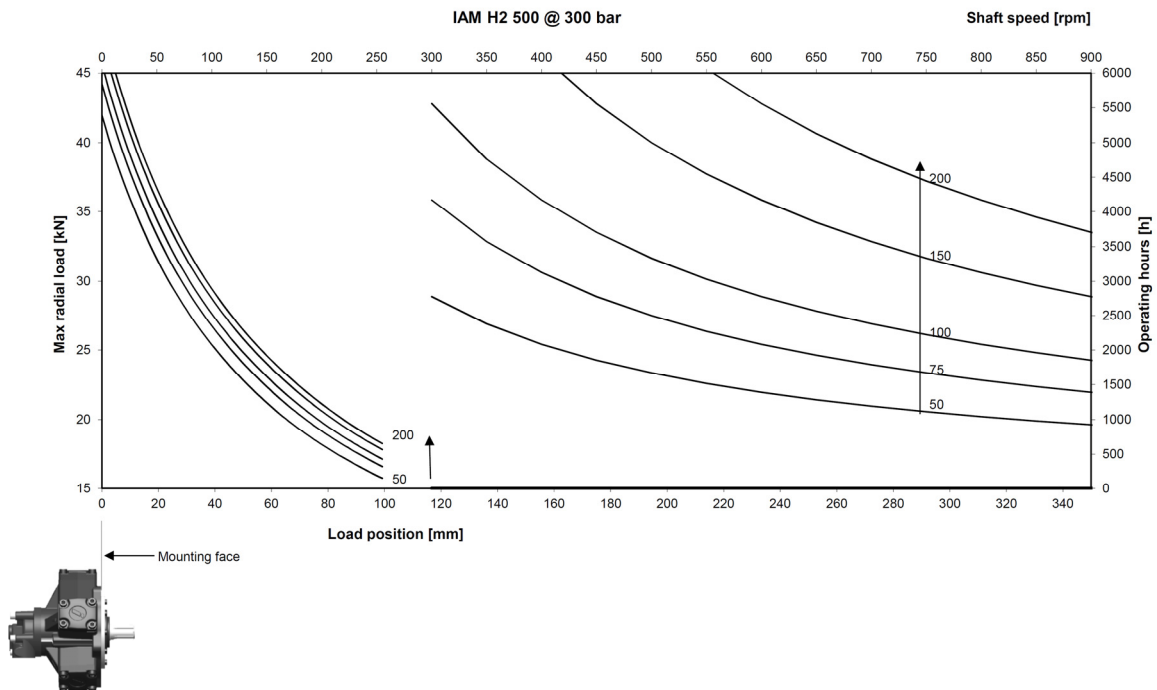
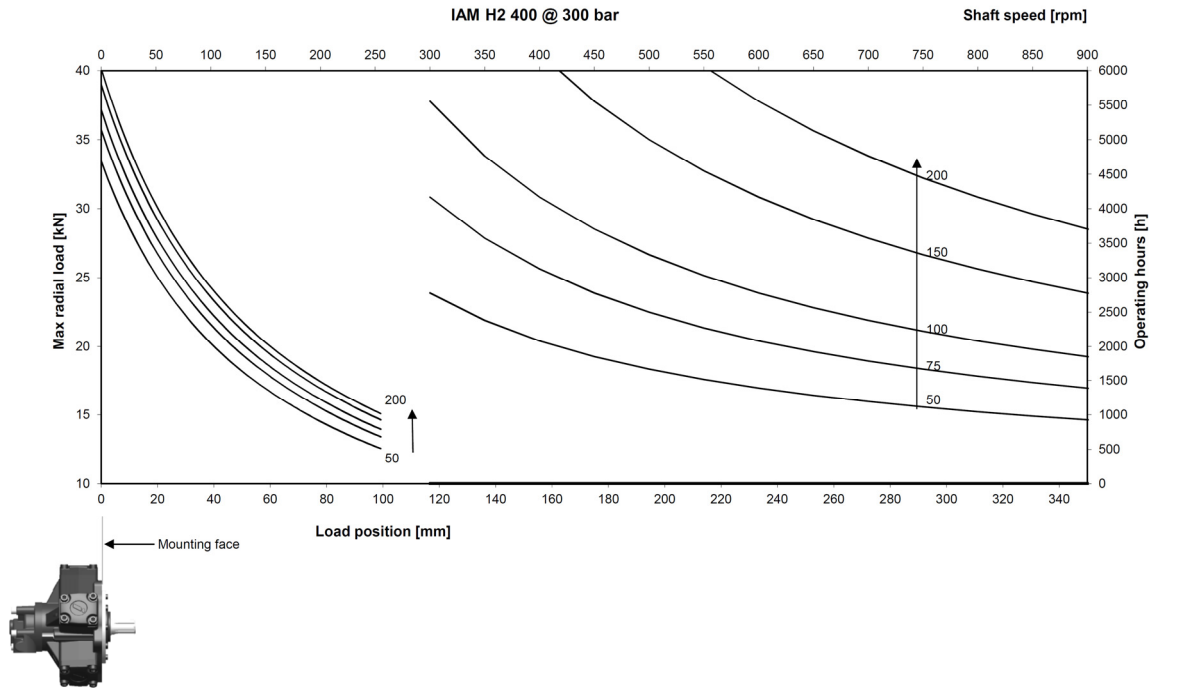

IAM+ H2

Side load charts

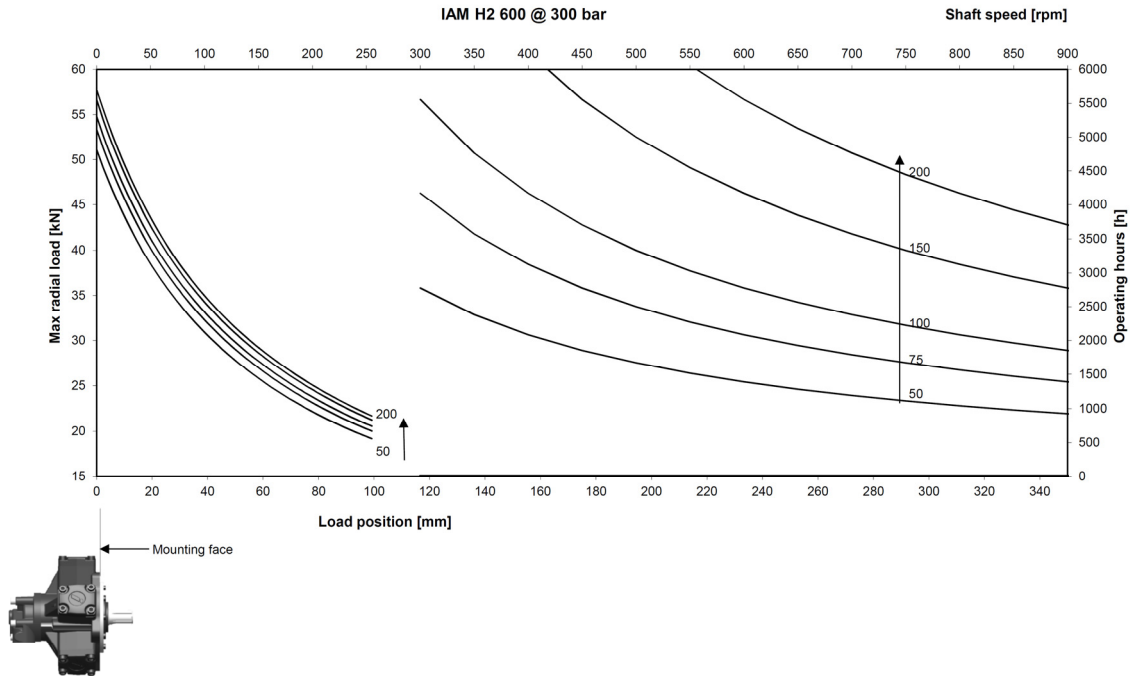

IAM+ H2

Ordering instructions

IAM+	---	H2	A _	D __	--	SB _
Model						
Displacement						
200 cc/rev						
250 cc/rev						
300 cc/rev						
350 cc/rev						
400 cc/rev						
500 cc/rev						
600 cc/rev						
Housing						
Shaft						
A0 – Standard splined shaft						
A2 – Parallel keyed shaft						
Distributor						
D31 – ¾" BSP						
D310 – 1" BSP						
D40 – 1" BSP						
D47 – SAE 1" 3000 psi flange						
Tachometer						
K						
TA						
TB						
EST						
Spline billet						
SB2 – 32 UNI 221						
SB3 – 36 UNI 221						

EXAMPLE : IAM+ 400 H2 A0 D40

IAM+ 200 H2 A0 D40 K SB2

Intermot Hydraulic Motors

IAM+ Series

H3 Models

IAM+ 400 – 500 – 600 – 700 H3

IAM+ 800 H3

INDEX

TECHNICAL DATA	Pag. 31
IAM+ 400 - 500 - 600 - 700 H3	Pag. 32
IAM+ 800 H3	Pag. 33
GRAPHIC PERFORMANCES	Pag. 34
ORDERING INSTRUCTIONS	Pag. 39

IAM+ H3

Technical data

MODEL	N° of pistons	Displacement	Specific Torque	Pressure			Speed		Max Power		Dry Mass	Max case pressure	Max back pressure	Temperature range	Minimum speed	Inertia moment of rotating parts
				Max Cont.	Max Int.	Peak	Max Cont.	Peak								
				cm ³ /rev	Nm/bar	bar										
IAM+ H3	400	404	6.4	300	350	400	600	680	110	82	68	6	70	-30 +70	1	214
	500	491	7.8	300	350	400	600	680	110	82						
	600	616	9.8	300	350	400	550	630	110	82						
	700	707	11.3	300	350	400	450	500	110	82						
	800	779	12.4	300	350	400	400	450	110	82						

IAM+ H3

Dimensional drawings

IAM+ 400 – 500 – 600 – 700 H3

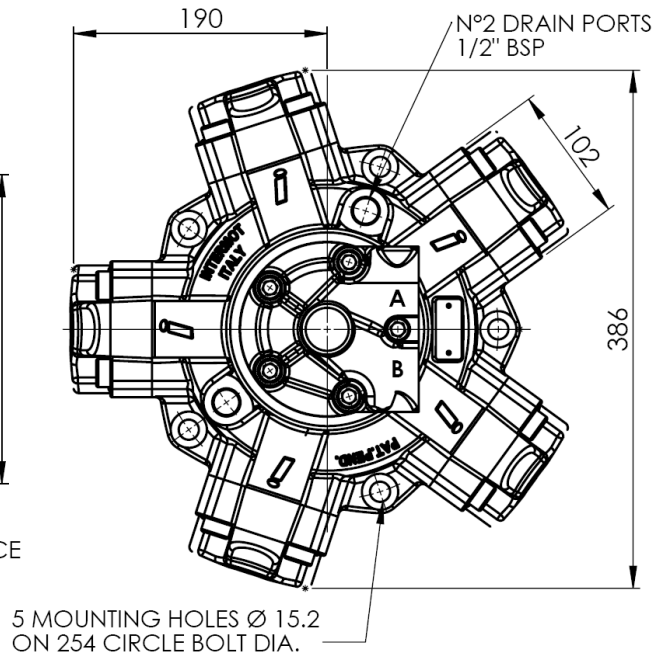
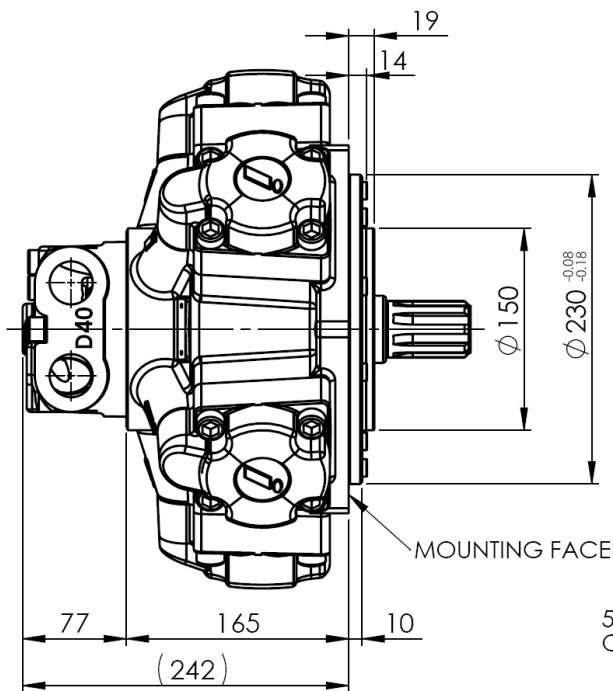

SHAFTS

A0: Standard splined shaft

A2: Parallel shaft on request

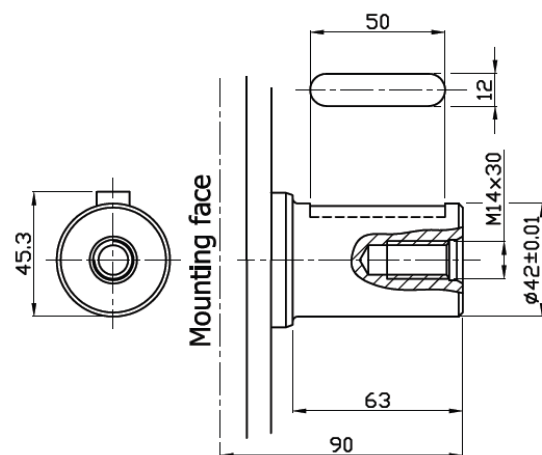
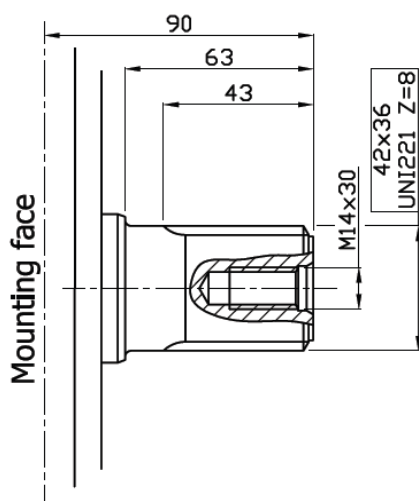

IAM+ 800 H3

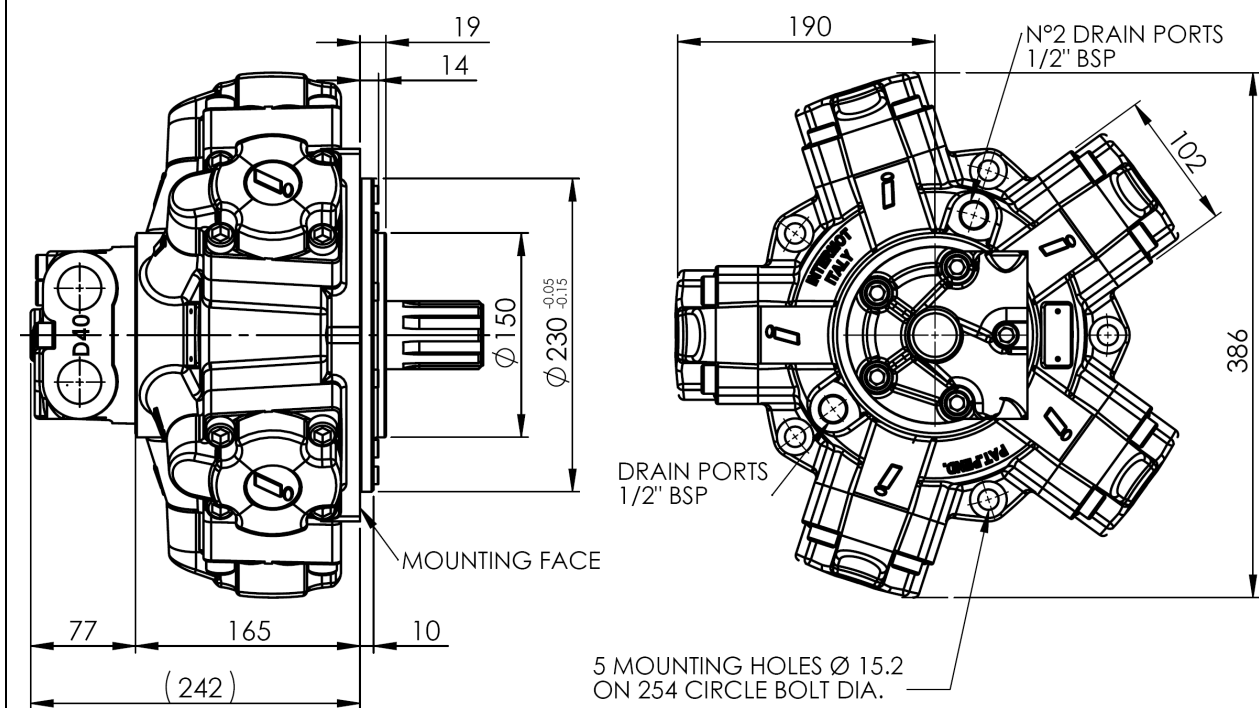

SHAFTS

A0: Standard splined shaft

A2: Parallel shaft on request

A22: Parallel shaft on request

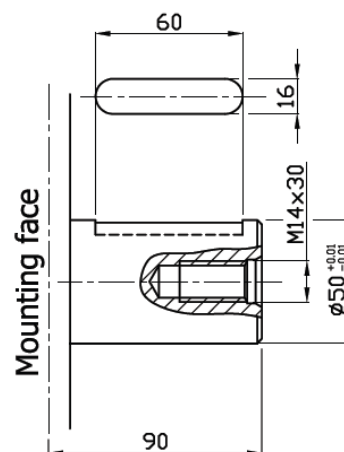
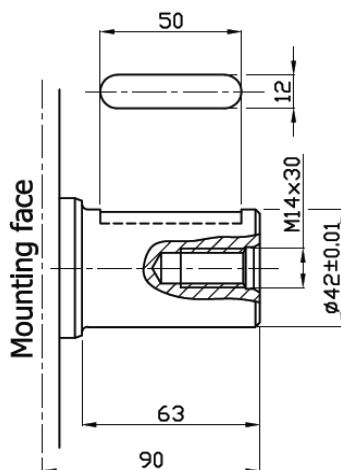
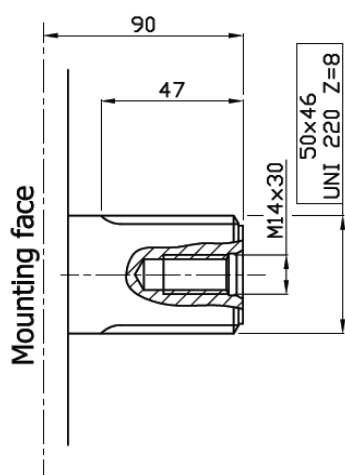

IAM+ H3

Power charts

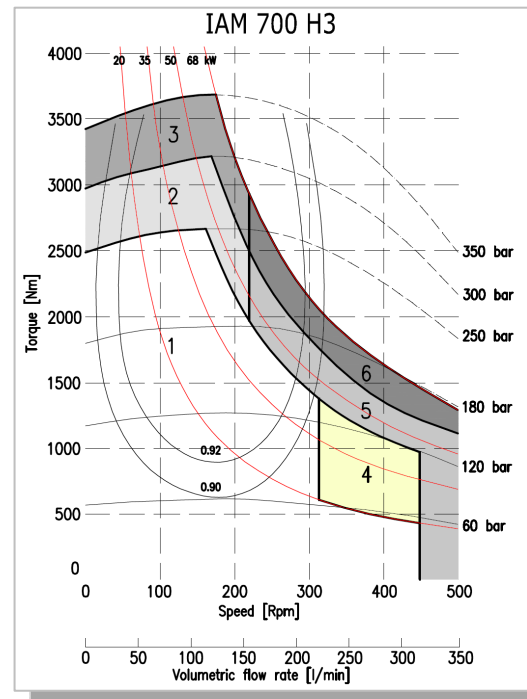
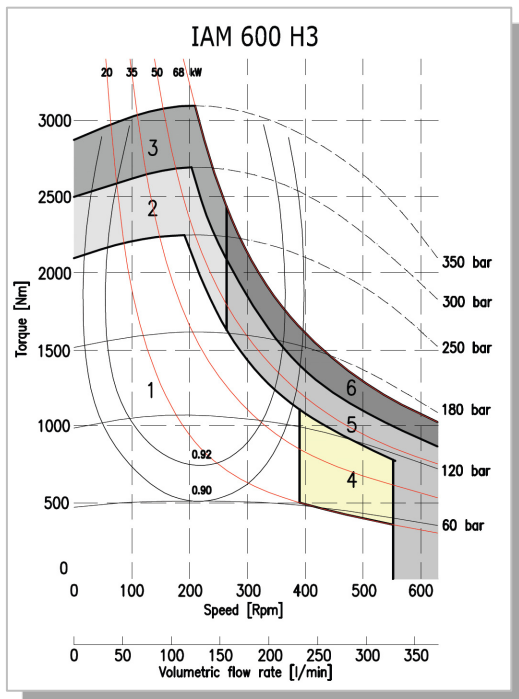
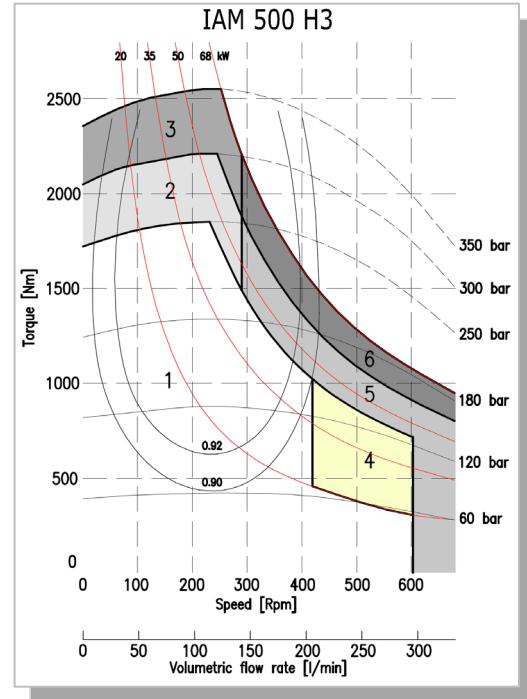
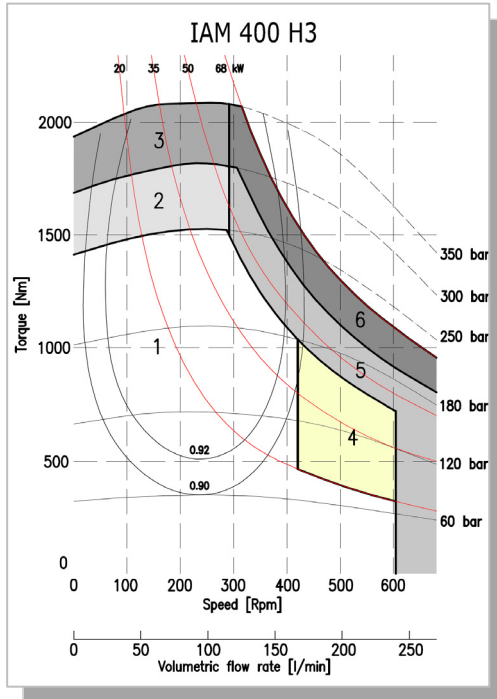

IAM+ H3

Power charts

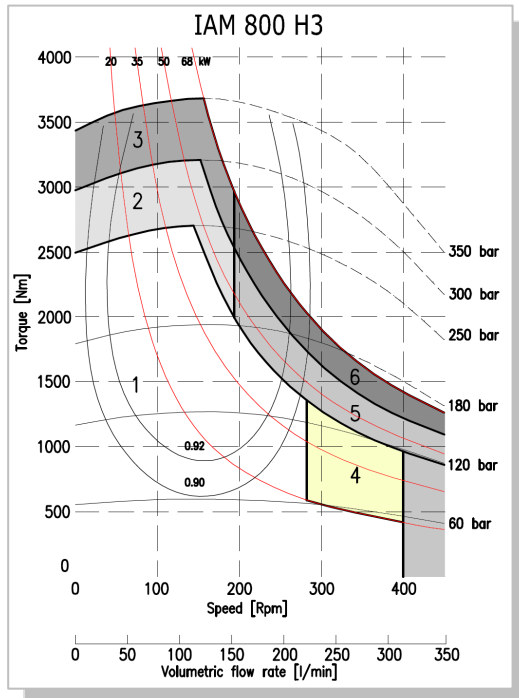

1	Continuous operation
2	Intermittent operation for period 3-5 minutes every 10-15 minutes
3	Intermittent operation for very short period (3-5 seconds every 10-15 minutes)
4	Continuous operation with flushing
5	Intermittent operation for period 3-5 minutes every 10-15 minutes with flushing
6	Intermittent operation for very short period (3-5 seconds every 10-15 minutes) with flushing

IAM+ H3

Side load charts

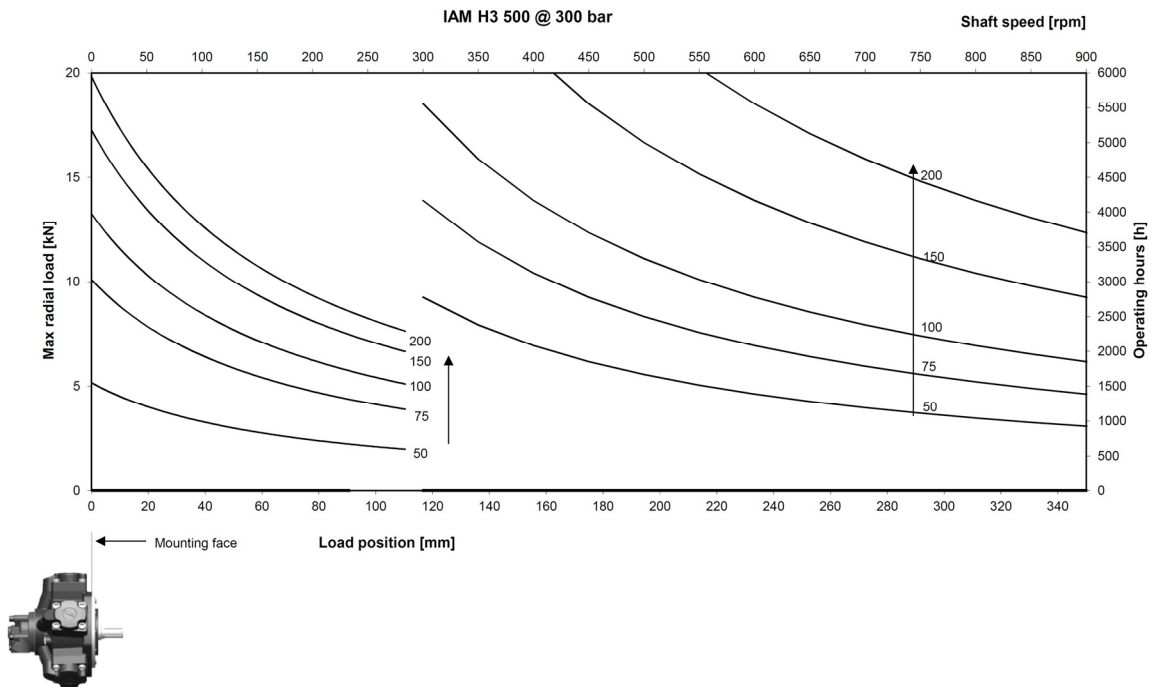
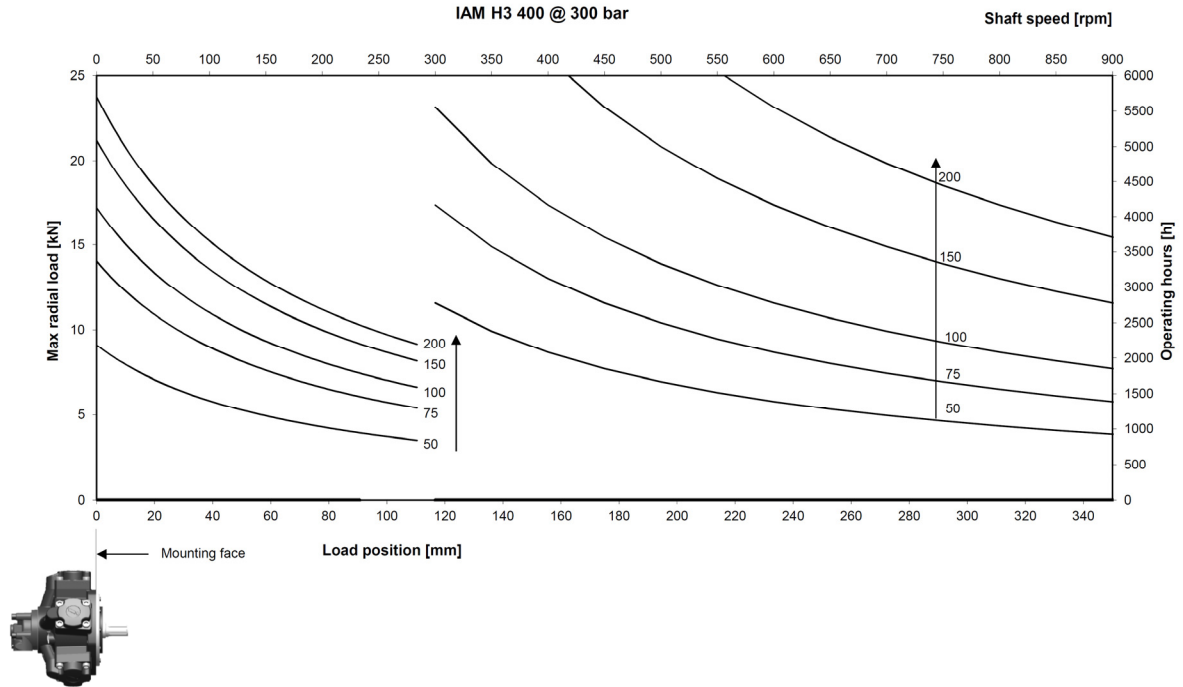

IAM+ H3

Side load charts

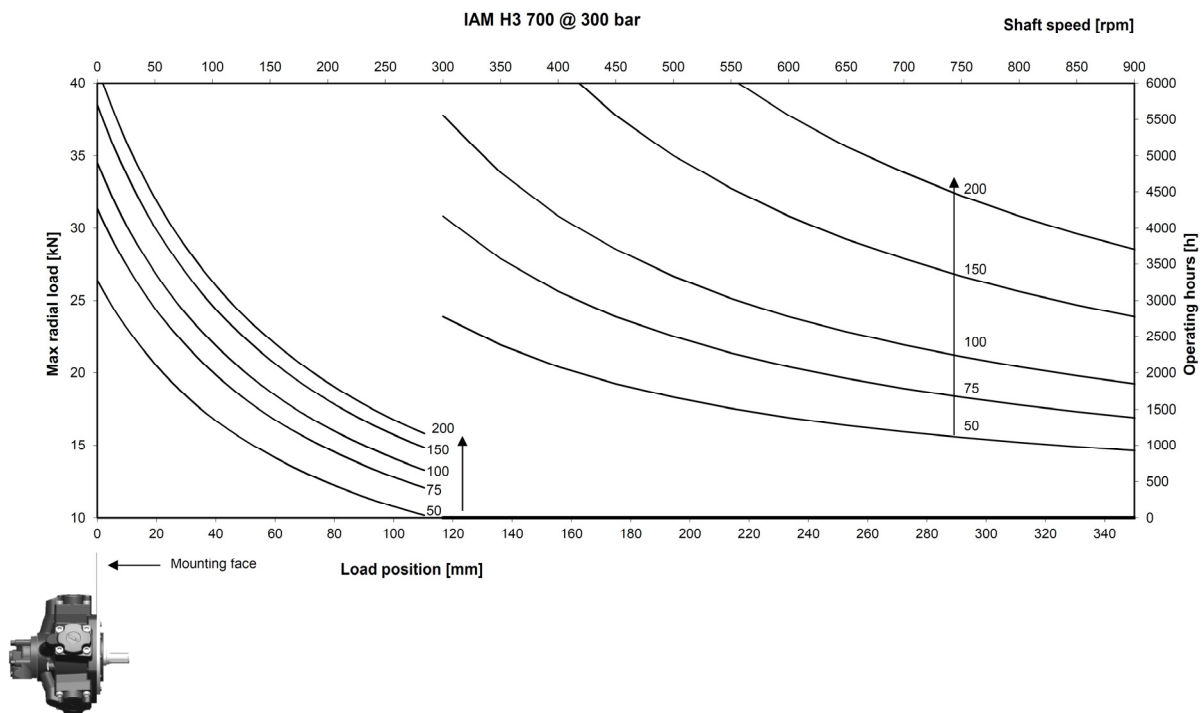
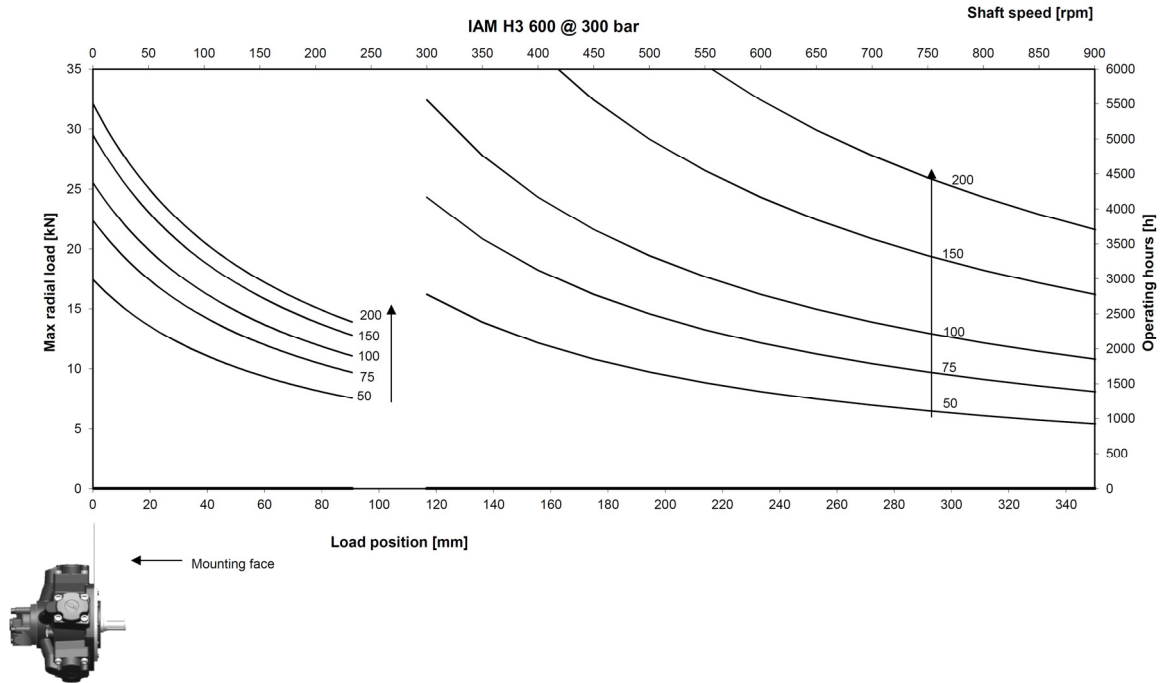

IAM+ H3

Side load charts

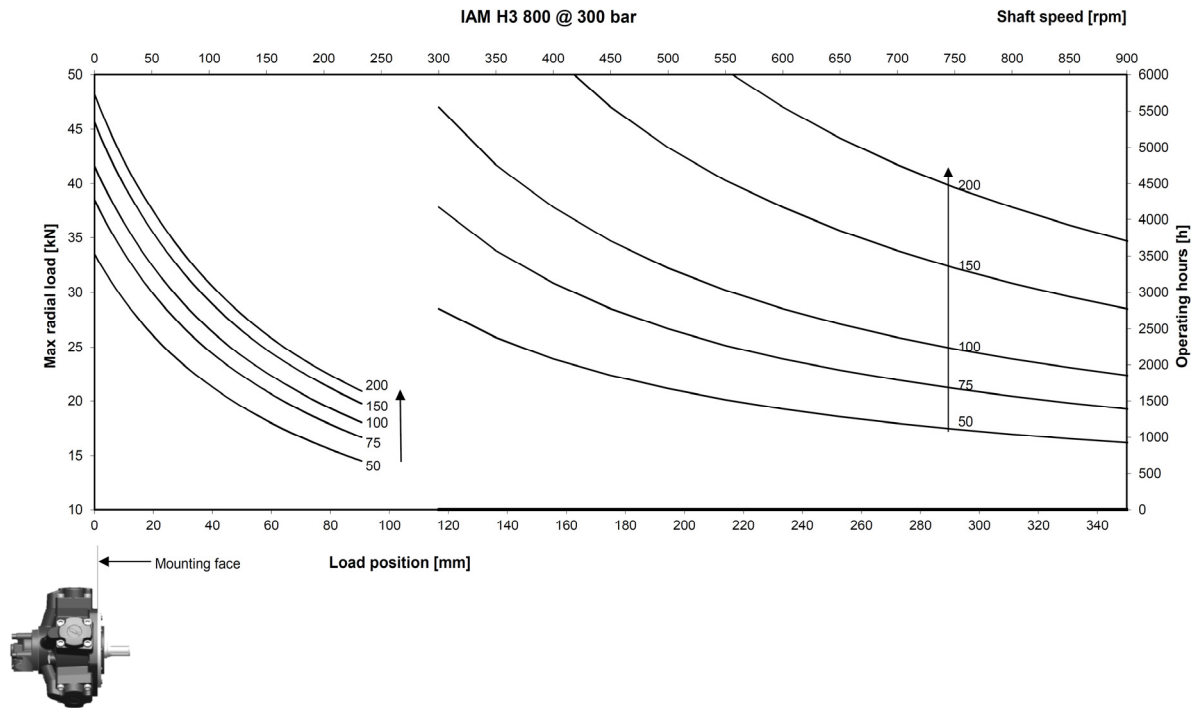

IAM+ H3

Ordering instructions

IAM+	---	H3	A _	D --	--	SB --
Model						
Displacement						
400 cc/rev						
500 cc/rev						
600 cc/rev						
700 cc/rev						
800 cc/rev						
Housing						
			Shaft			
A0 – Standard splined shaft						
A2 – Parallel keyed shaft						
A22 – Parallel keyed shaft						
				Distributor		
D31 – ¾" BSP						
D310 – 1" BSP						
D40 – 1" BSP						
D47 – SAE 1" 3000 psi flange						
					Tachometer	
K						
TA						
TB						
EST						
						Spline billet
SB3 – 36 UNI 221						
SB4 – 46 UNI 220						

EXAMPLE : IAM+ 600 H3 A0 D40

IAM+ 700 H3 A0 D40 TA SB3

Intermot Hydraulic Motors

IAM+ Series

H4 Models

IAM+ 800 – 900 – 1000 – 1100 – 1200 – 1300 – 1400 H4

INDEX

TECHNICAL DATA	Pag. 41
IAM+ 800 - 900 - 1000 - 1100	
1200 - 1300 - 1400 H4	Pag. 42
GRAPHIC PERFORMANCES	Pag. 43
ORDERING INSTRUCTIONS	Pag. 48

IAM+ H4

Technical data

MODEL		N° of pistons	Displacement	Specific Torque	Pressure			Speed		Max Power		Dry Mass	Max case pressure	Max back pressure	Temperature range	Minimum speed	Inertia moment of rotating parts
					Max Cont.	Max Int.	Peak	Max Cont.	Peak								
					cm ³ /rev	Nm/bar	bar										
IAM+ H4	800	5	764	12.2	300	350	400	450	530	129	96	92	6	70	-30 ÷ +70	1	267
	900		877	14.0	300	350	400	450	530	129	96						
	1000		966	15.4	300	350	400	300	400	129	96						
	1100		1093	17.4	300	350	400	300	400	129	96						
	1200		1193	19.0	300	350	400	300	350	129	96						
	1300		1333	21.2	300	30	400	230	280	129	96						
	1400		1406	22.4	300	350	400	230	280	129	96						

The data specified into this catalogue are for product description purpose only and must not be interpreted as warranted characteristic in legal sense. Intermot reserves the right to implement modification without notice. **41**

IAM+ H4

Dimensional drawings

IAM+ 800 – 900 – 1000 – 1100 – 1200 – 1300 – 1400 H4

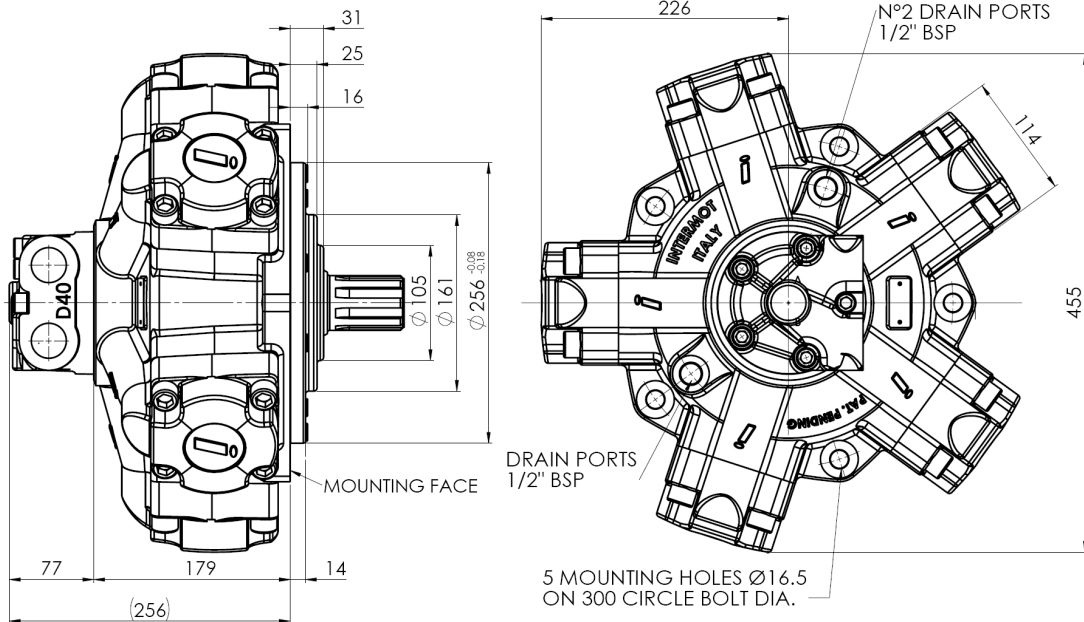

SHAFTS

A0: Standard splined shaft

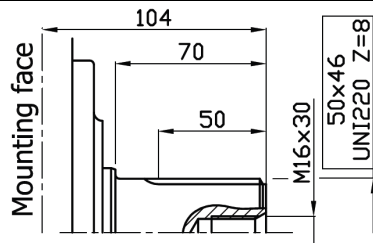

A1: Splined shaft on request

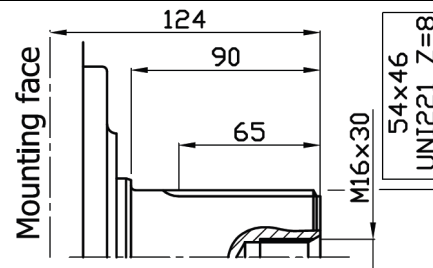

A2: Parallel shaft on request

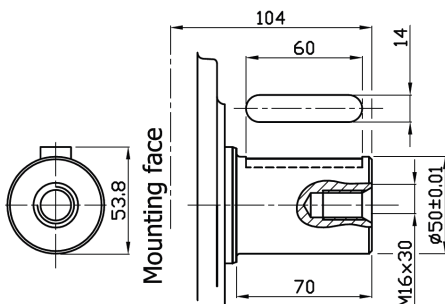

A3: Female shaft on request

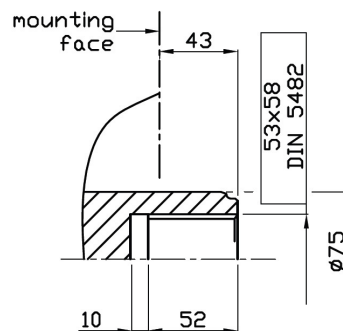

IAM+ H4

Power charts

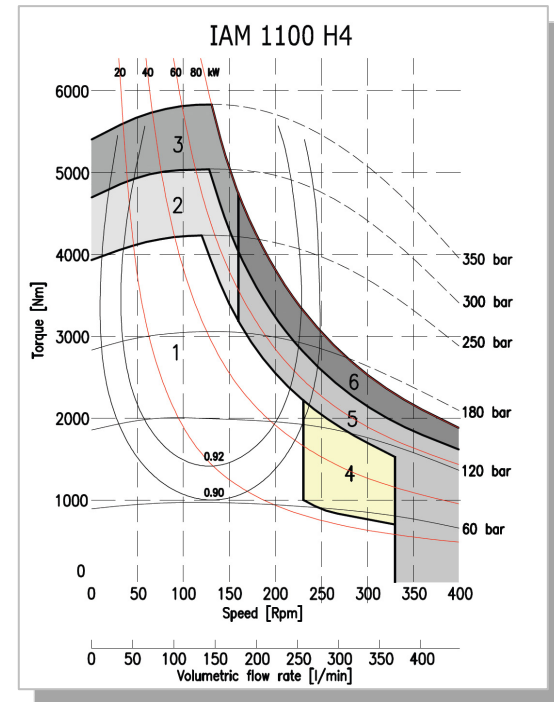
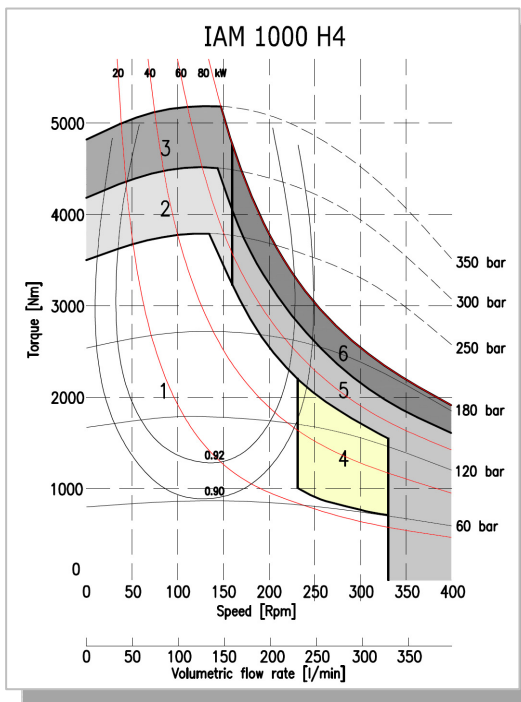
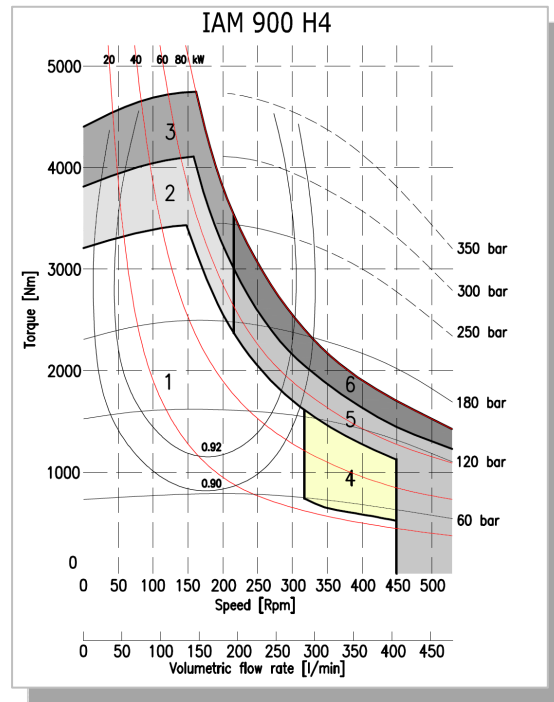
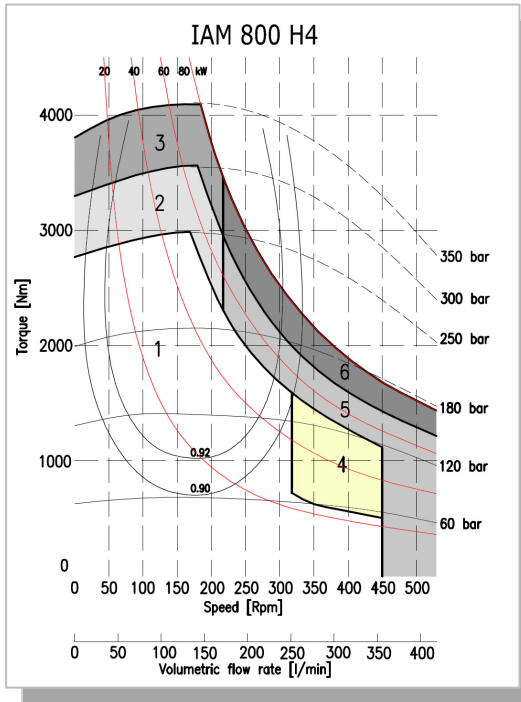

IAM+ H4

Power charts

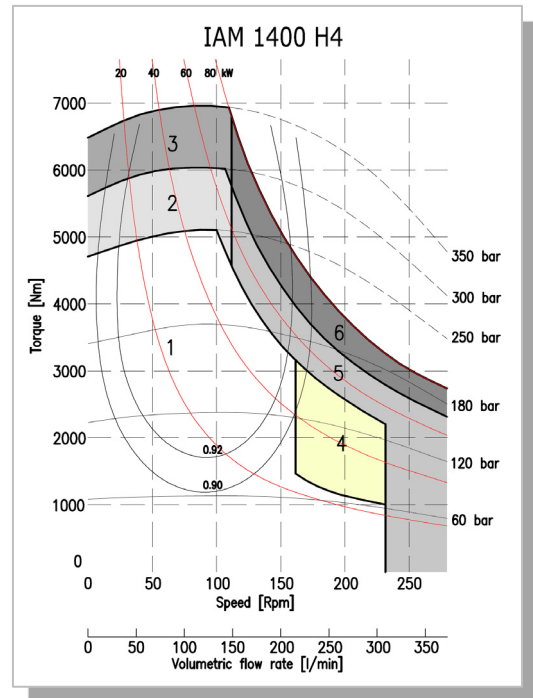
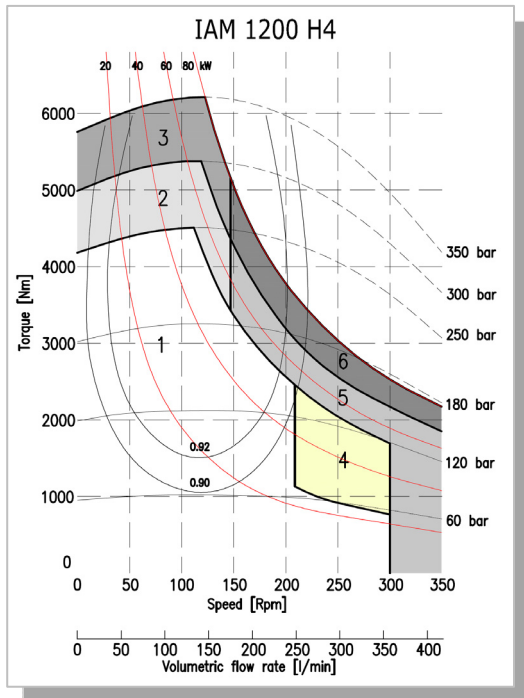

1	Continuous operation	4	Continuous operation with flushing
2	Intermittent operation for period 3-5 minutes every 10-15 minutes	5	Intermittent operation for period 3-5 minutes every 10-15 minutes with flushing
3	Intermittent operation for very short period (3-5 seconds every 10-15 minutes)	6	Intermittent operation for very short period (3-5 seconds every 10-15 minutes) with flushing

IAM+ H4

Side load charts

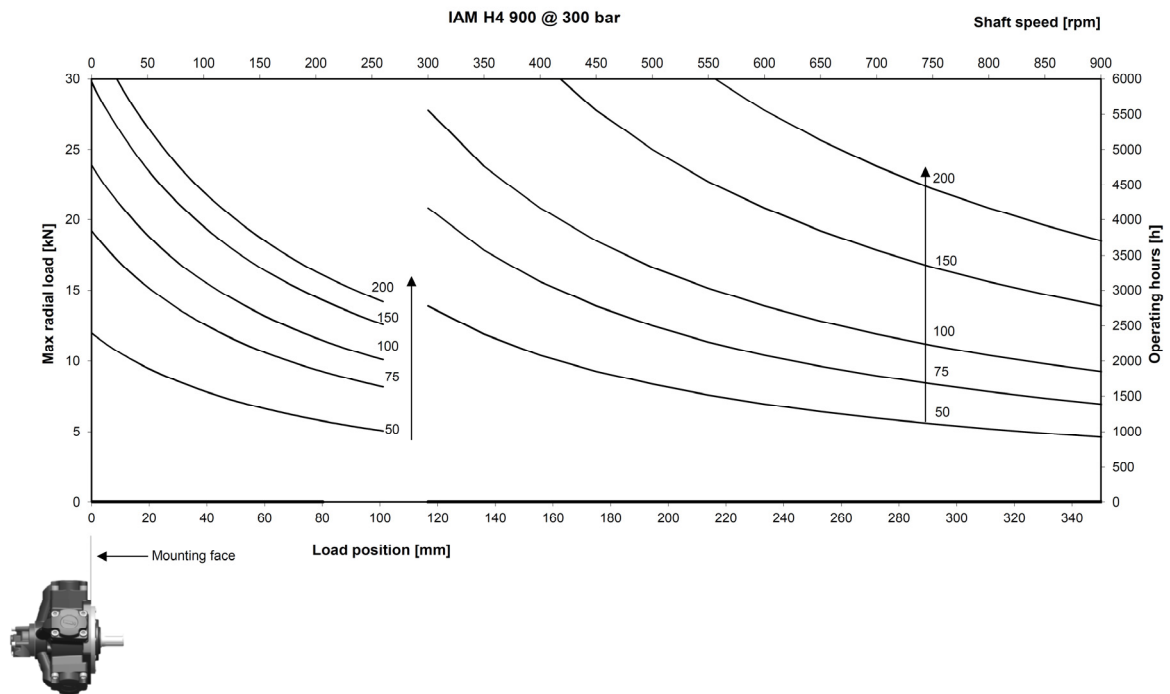
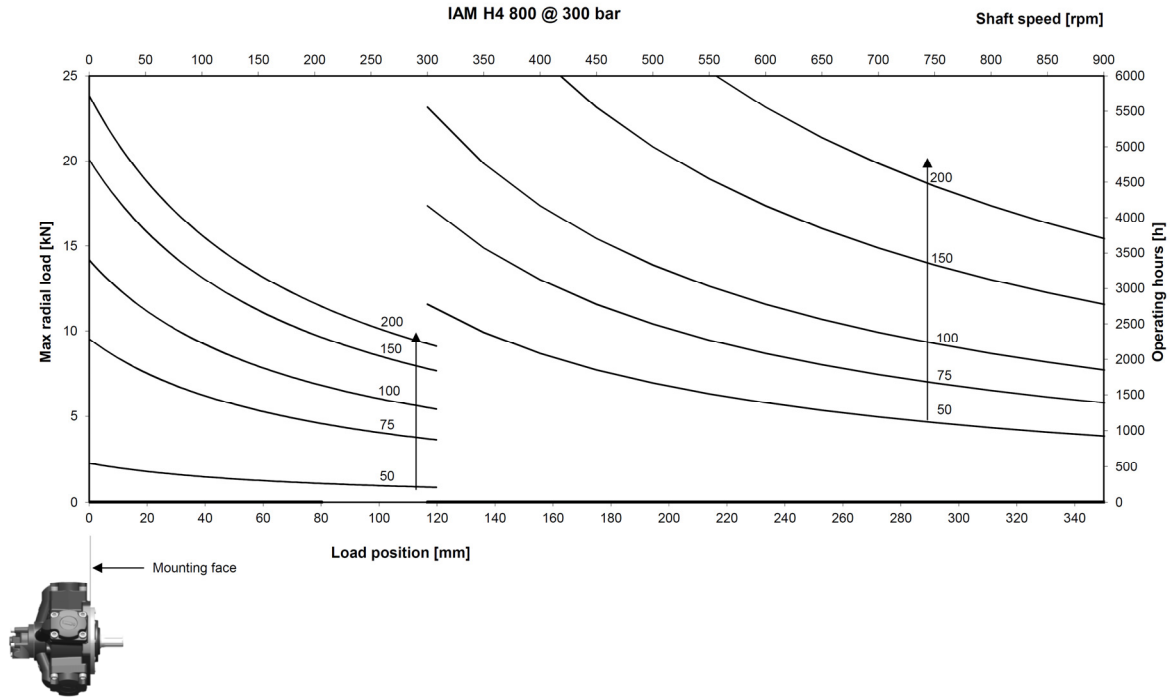

IAM+ H4

Side load charts

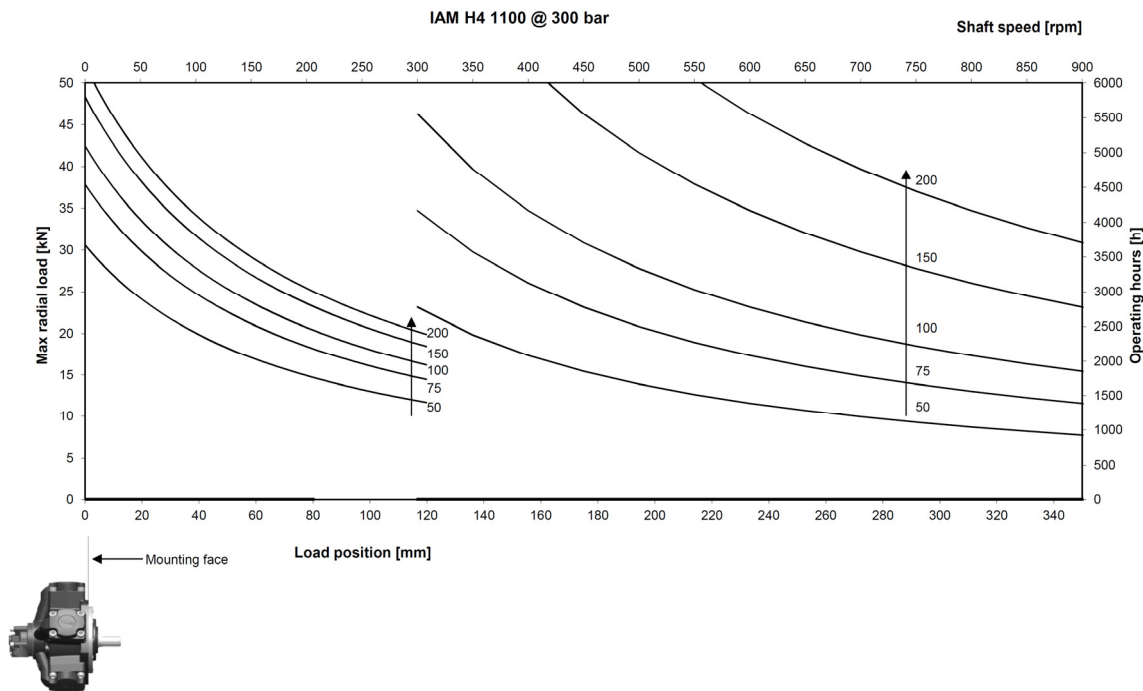
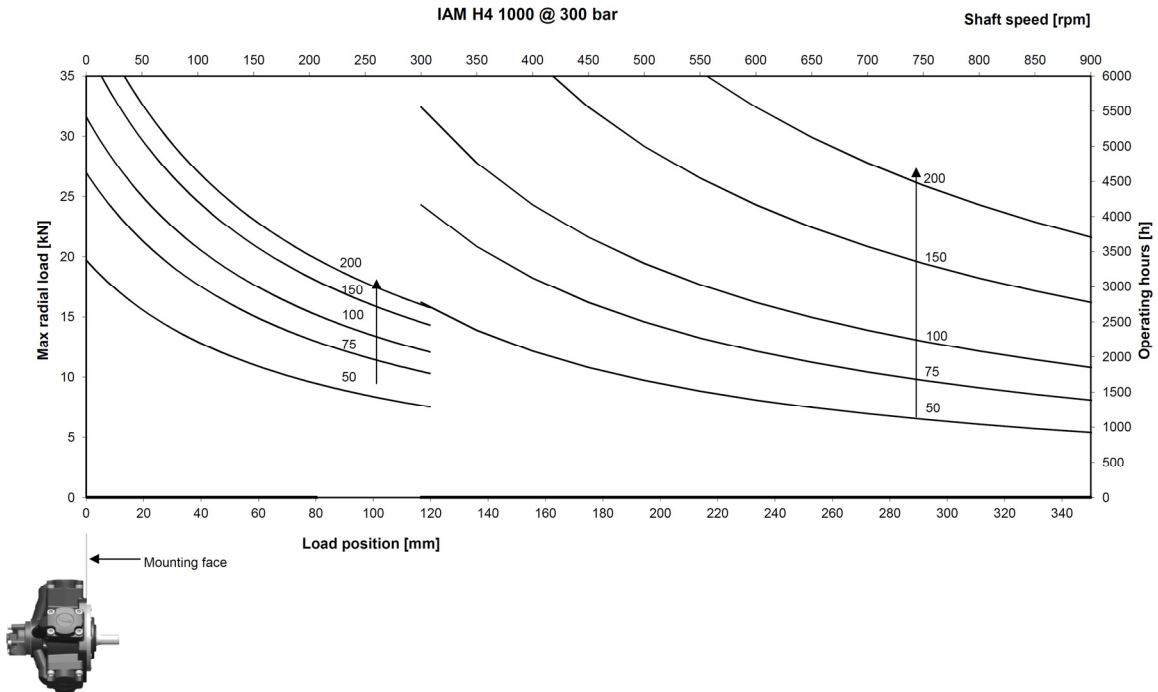

IAM+ H4

Side load charts

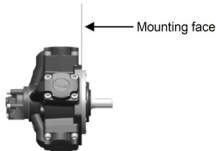
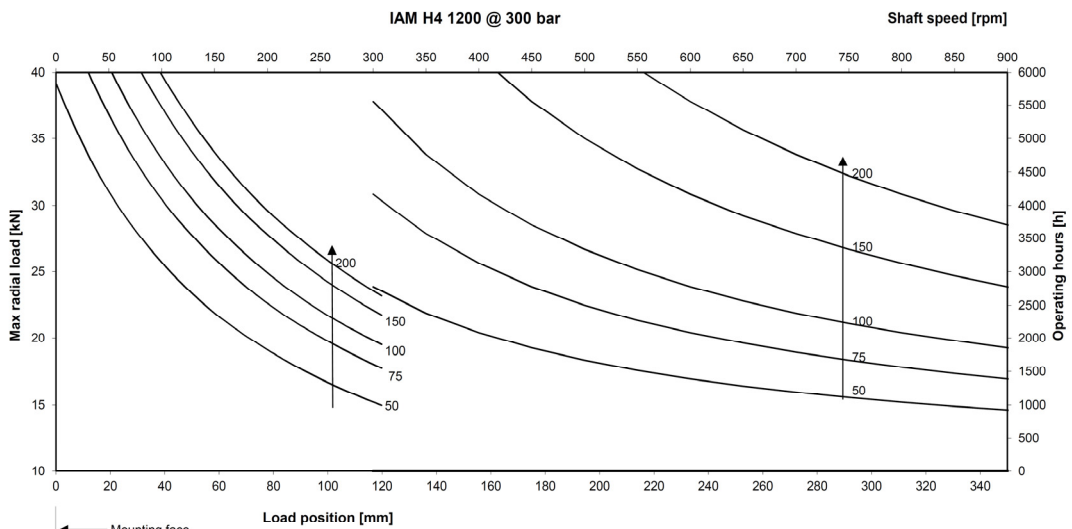
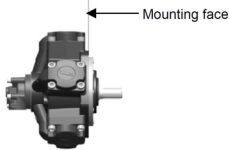
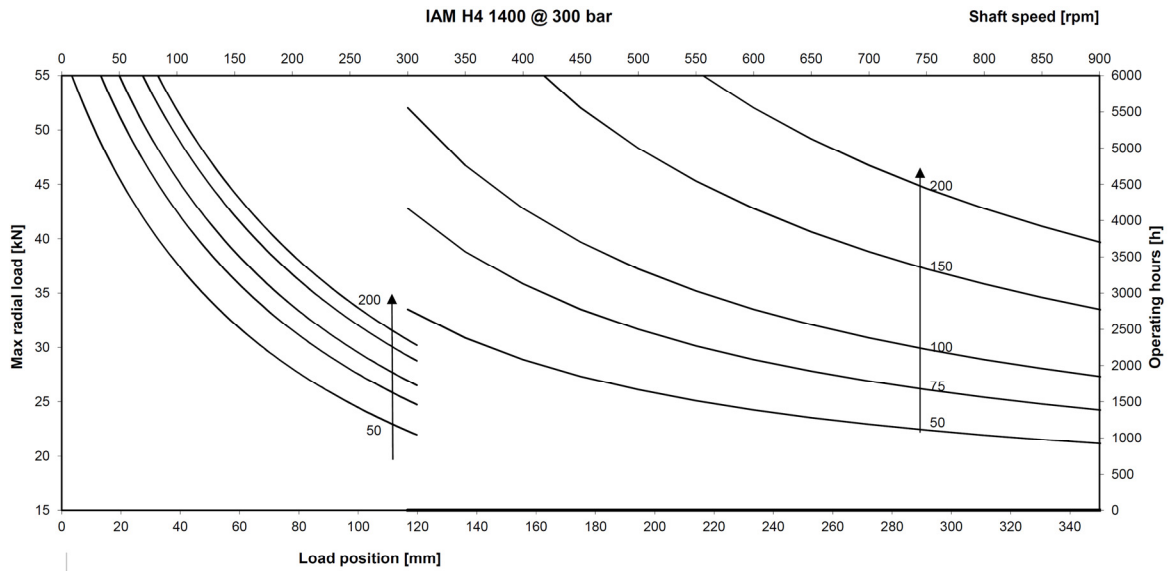

IAM+ H4

Ordering instructions

IAM+	---	H4	A _	D __	--	SB _
Model						
Displacement						
800 cc/rev						
900 cc/rev						
1000 cc/rev						
1100cc/rev						
1200 cc/rev						
1300 cc/rev						
1400 cc/rev						
Housing						
			Shaft			
A0 – Standard splined shaft						
A1 – Special splined shaft						
A2 – Parallel keyed shaft						
A3 – Female shaft						
				Distributor		
D31 – ¾" BSP						
D310 – 1" BSP						
D40 – 1" BSP						
D47 – SAE 1" 3000 psi flange						
					Tachometer	
K						
TA						
TB						
EST						
						Spline billet
SB4 – 46 UNI 220						
SB5 – 46 UNI 221						

EXAMPLE : IAM+ 800 H4 A0 D40

IAM+ 1000 H4 A0 D40 EST SB4

Intermot Hydraulic Motors
IAM+ Series

H5 Models

IAM+ 1200 – 1400 – 1600 – 1800 – 2000 – 2200 H5

INDEX

TECHNICAL DATA	Pag. 50
IAM+ 1200 - 1400 - 1600 - 1800	
2000 - 2200 H5	Pag. 51
GRAPHIC PERFORMANCES	Pag. 52
ORDERING INSTRUCTIONS	Pag. 57

MODEL		N° of pistons	Displacement	Specific Torque	Pressure			Speed		Max Power		Dry Mass	Max case pressure	Max back pressure	Temperature range	Minimum speed	Inertia moment of rotating parts
					Max Cont.	Max Int.	Peak	Max Cont.	Peak								
			cm ³ /rev	Nm/bar	bar			rpm		hp	kW	kg	bar	bar	°C	rpm	kg cm ²
IAM+ H5	1200	5	1232	19.6	300	350	400	300	350	193	144	173	6	70	-30 ÷ +70	0.5	697
	1400		1376	21.9	300	350	400	300	350	193	144	173					
	1600		1690	26.9	300	350	400	300	340	193	144	173					
	1800		1816	28.9	300	350	400	250	300	193	144	173					
	2000		2127	33.9	300	350	400	230	260	193	144	173					
	2200		2221	35.3	300	350	400	220	240	193	144	173					

IAM+ H5

Dimensional drawings

IAM+ 1200 – 1400 – 1600 – 1800 – 2000 – 2200 H5

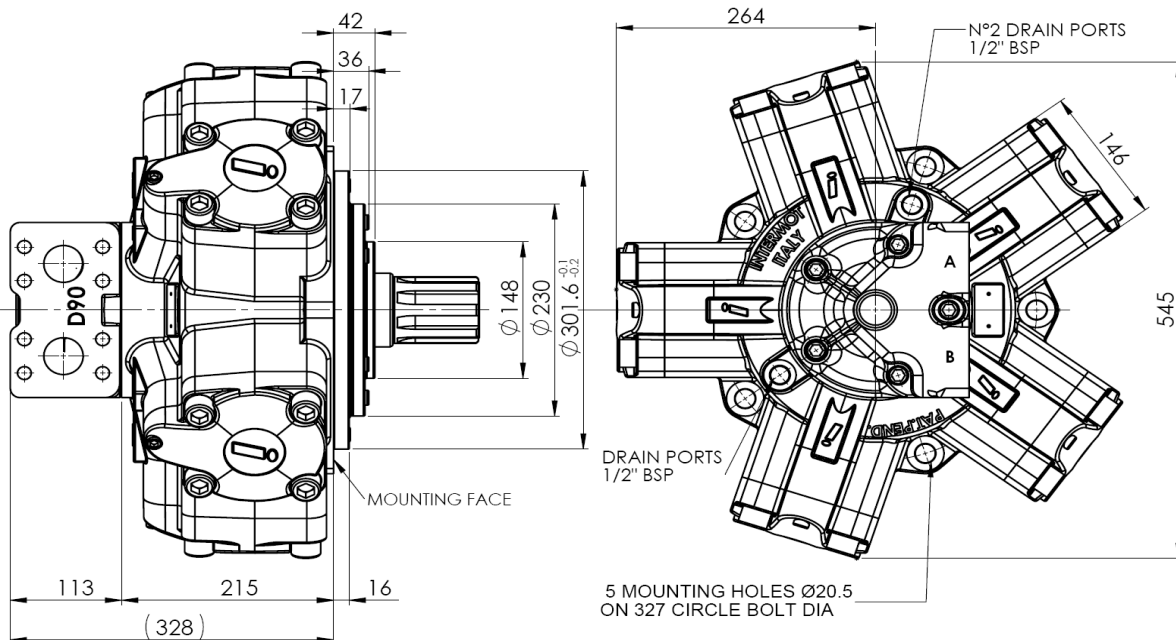

SHAFTS

A0: Standard splined shaft

A1: Splined shaft on request

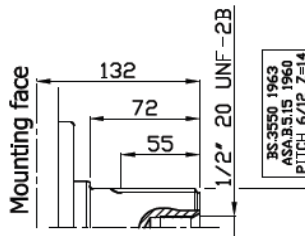
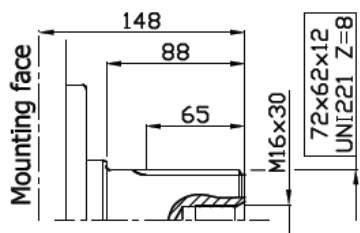

A2: Parallel shaft on request

A3: Female shaft on request

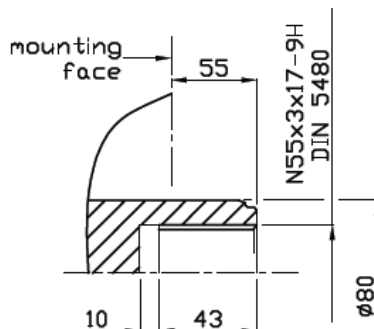
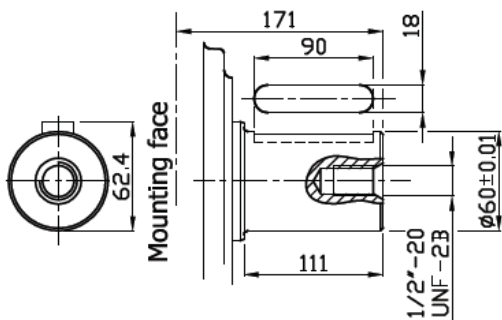

IAM+ H5

Power charts

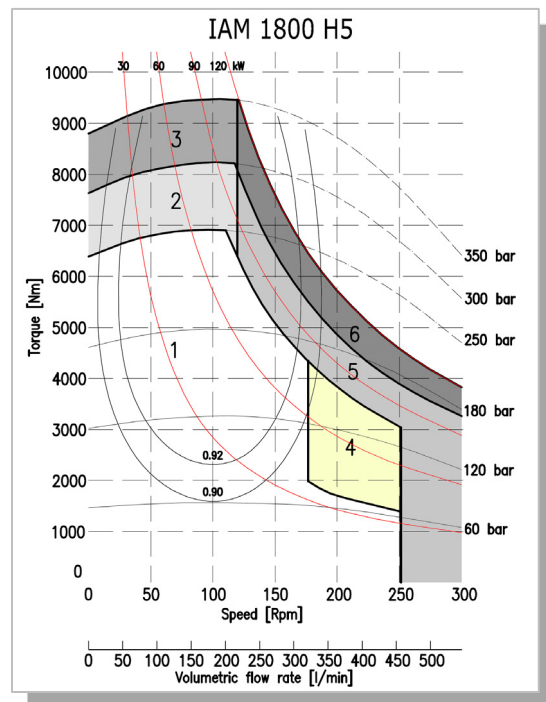
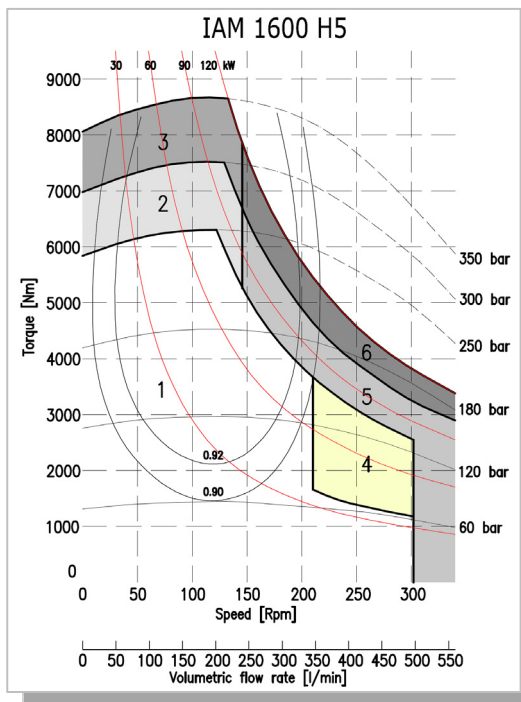
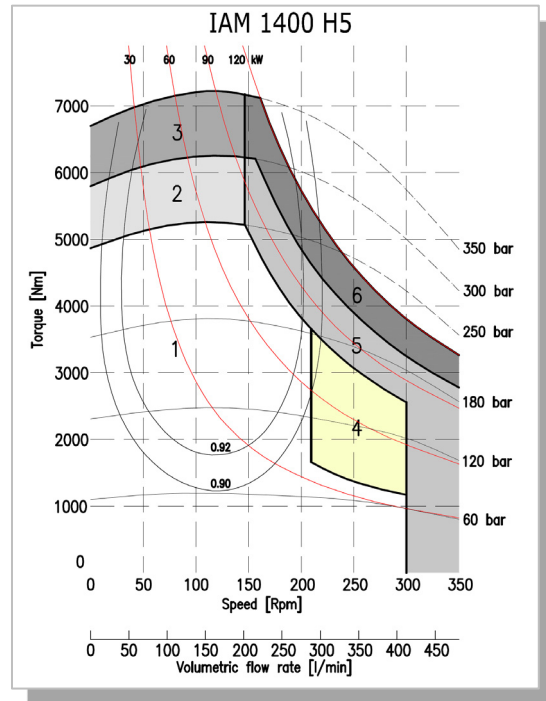
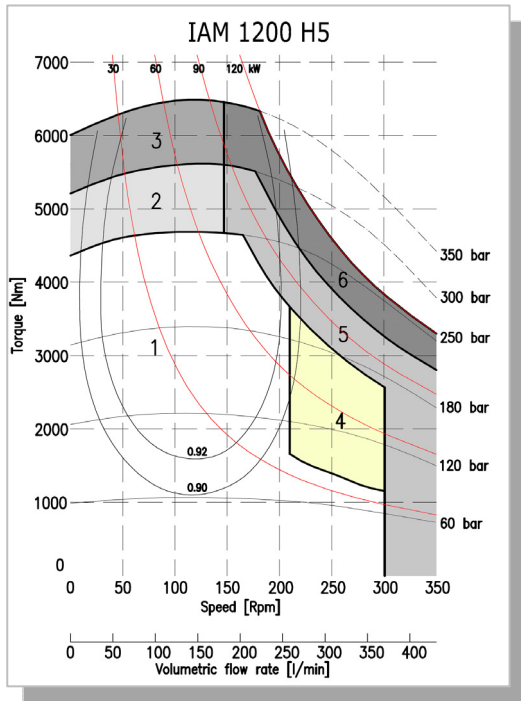

IAM+ H5

Power charts

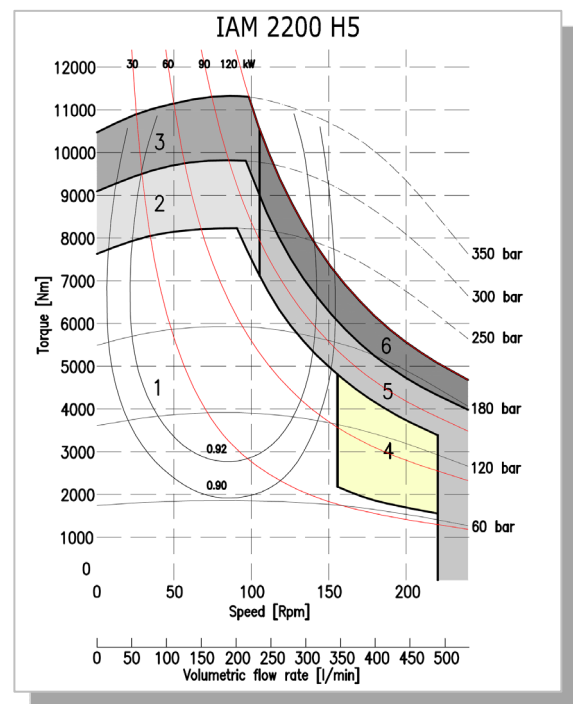
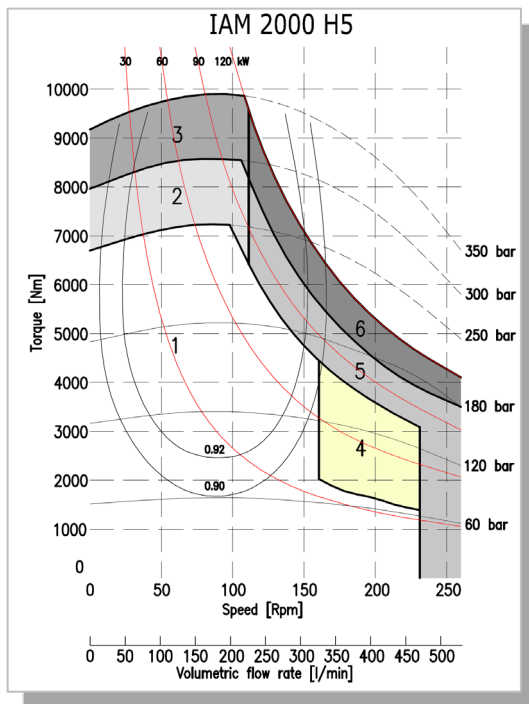

1	Continuous operation	4	Continuous operation with flushing
2	Intermittent operation for period 3-5 minutes every 10-15 minutes	5	Intermittent operation for period 3-5 minutes every 10-15 minutes with flushing
3	Intermittent operation for very short period (3-5 seconds every 10-15 minutes)	6	Intermittent operation for very short period (3-5 seconds every 10-15 minutes) with flushing

IAM+ H5

Side load charts

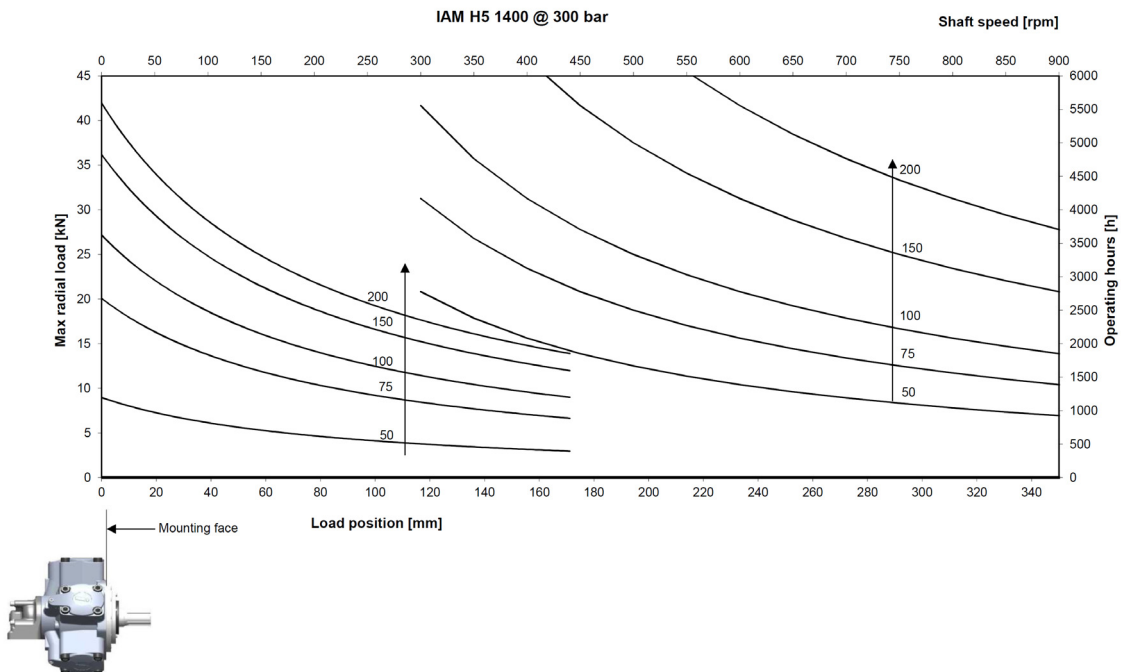
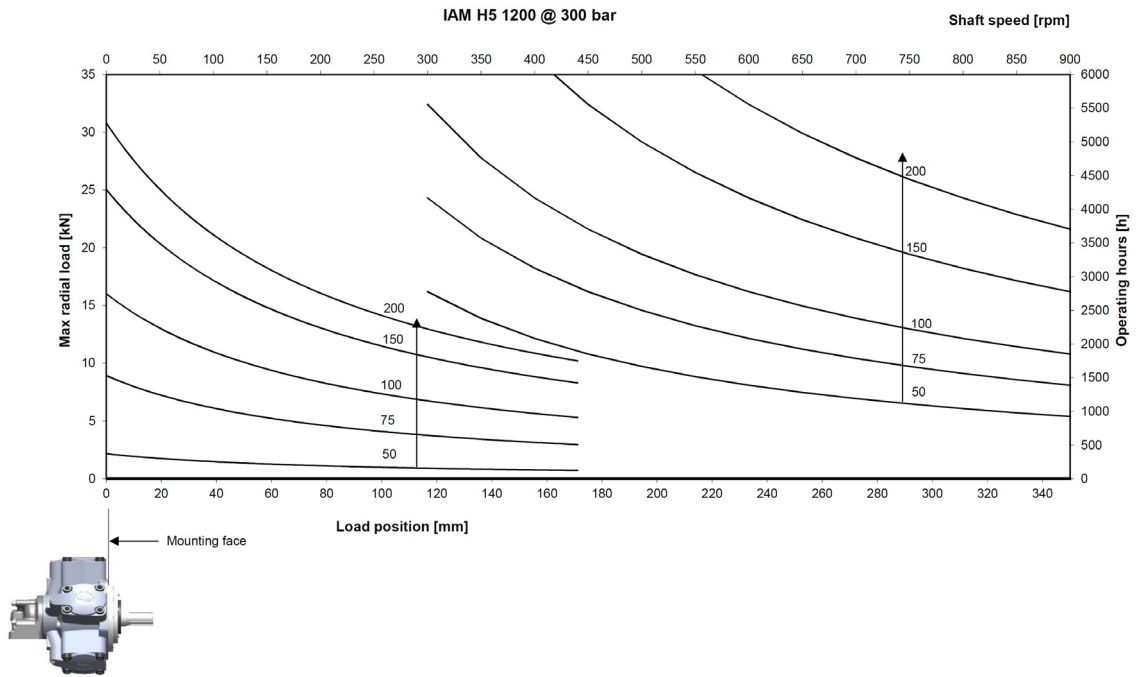

IAM+ H5

Side load charts

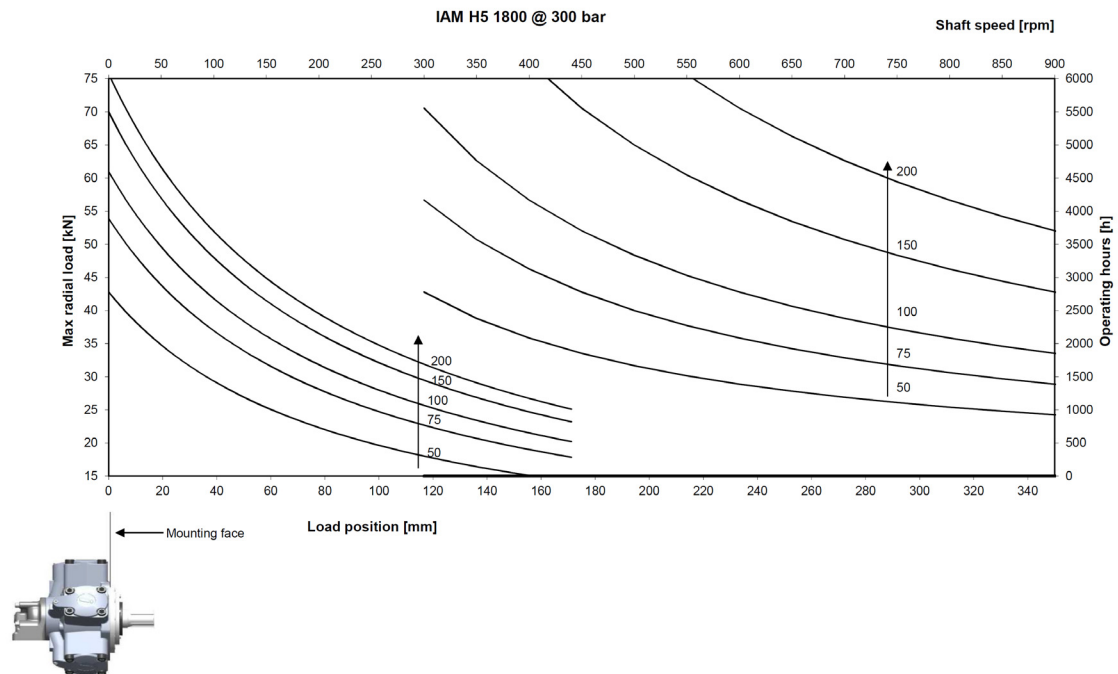
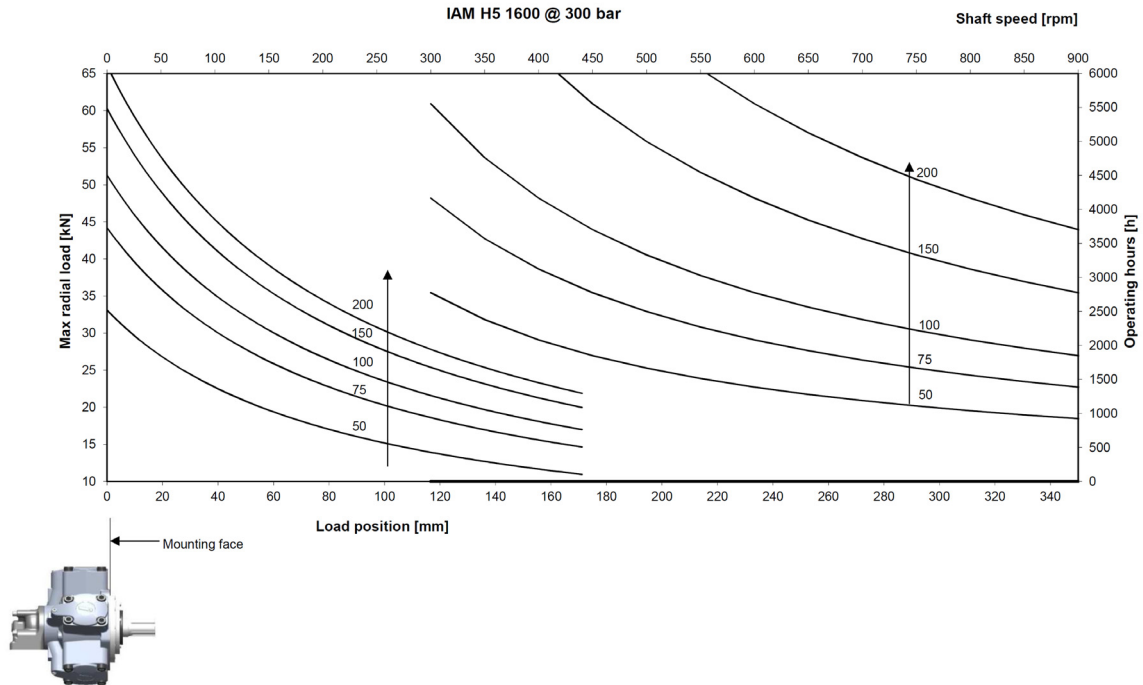

IAM+ H5

Side load charts

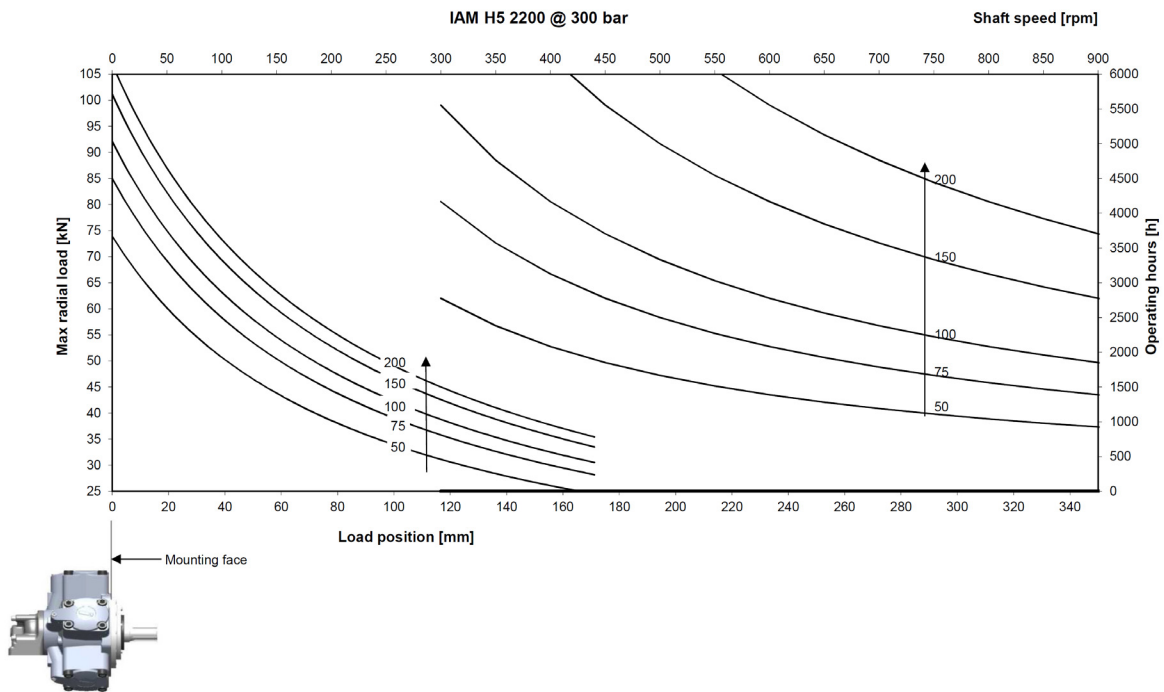
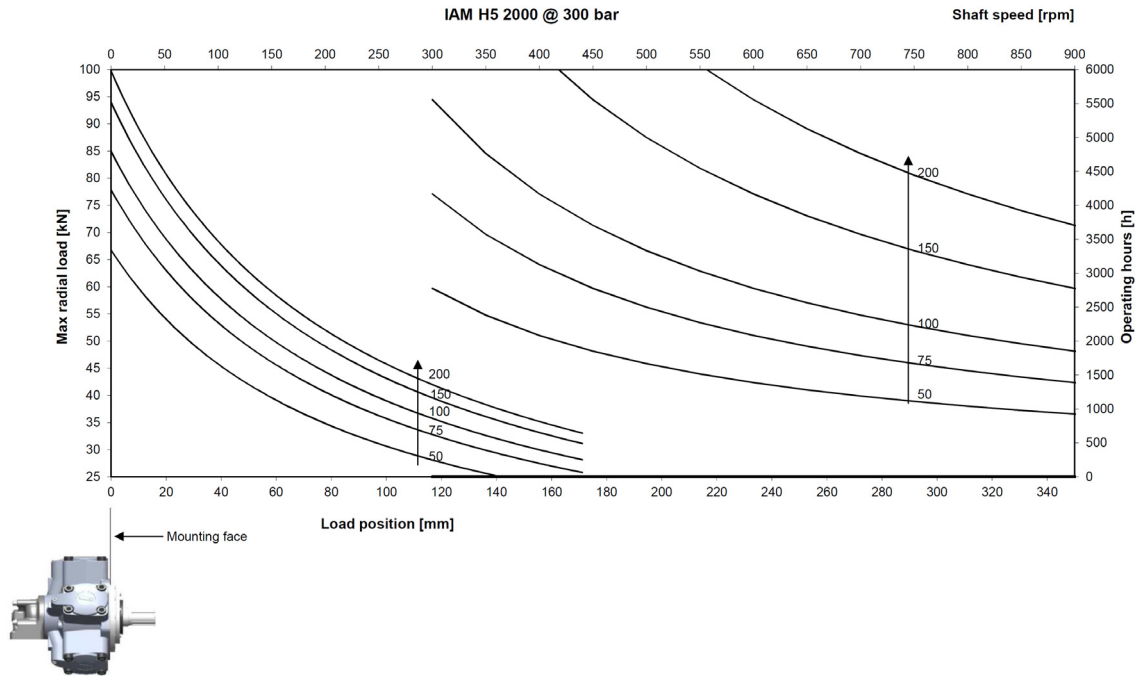

IAM+ H5

Ordering instructions

IAM+	---	H5	A _	D --	--	SB --
Model						
Displacement						
1200 cc/rev						
1400 cc/rev						
1600 cc/rev						
1800 cc/rev						
2000 cc/rev						
2200 cc/rev						
Housing						
			Shaft			
A0 – Standard splined shaft						
A1 – Special splined shaft						
A2 – Parallel keyed shaft						
A3 – Female shaft						
				Distributor		
D90 – SAE 1 ½ “ 6000 psi flange						
					Tachometer	
K						
TA						
TB						
EST						
						Spline billet
SB6 – 62 UNI 221						
SB7 – BS 3550 14 T 6/12						

EXAMPLE : IAM+ 1800 H5 A0 D90

IAM+ 2000 H5 A1 D90 TA SB6

Intermot Hydraulic Motors

IAM+ Series

H6 Models

IAM+ 2200-2500-2800-3000-3200-3500 H6

INDEX

TECHNICAL DATA	Pag. 59
IAM+ 2200 - 2500 - 3000 - 3200 - 3500 - H6	Pag. 60
GRAPHIC PERFORMANCES	Pag. 61
ORDERING INSTRUCTIONS	Pag. 66

IAM+ H6

Technical data

MODEL	N° of pistons	Displacement	Specific Torque	Pressure			Speed		Max Power		Dry Mass	Max case pressure	Max back pressure	Temperature range	Minimum speed	Inertia moment of rotating parts
				Max Cont.	Max Int.	Peak	Max Cont.	Peak								
				cm ³ /rev	Nm/bar	bar										
IAM+ H6	2200	2207	35.1	300	350	400	220	260	286	213	308	6	70	-30 +70	0.5	1745
	2500	2526	40.2	300	350	400	220	260	286	213	308					
	2800	2808	44.7	300	350	400	220	260	286	213	308					
	3000	2985	47.5	300	350	400	210	250	286	213	308					
	3200	3290	52.4	300	350	400	200	240	286	213	308					
	3500	3481	55.4	300	350	400	200	240	286	213	308					

IAM+ H6

Dimensional drawings

IAM+ 2200 – 2500 – 2800 – 3000 – 3200 – 3500 H6

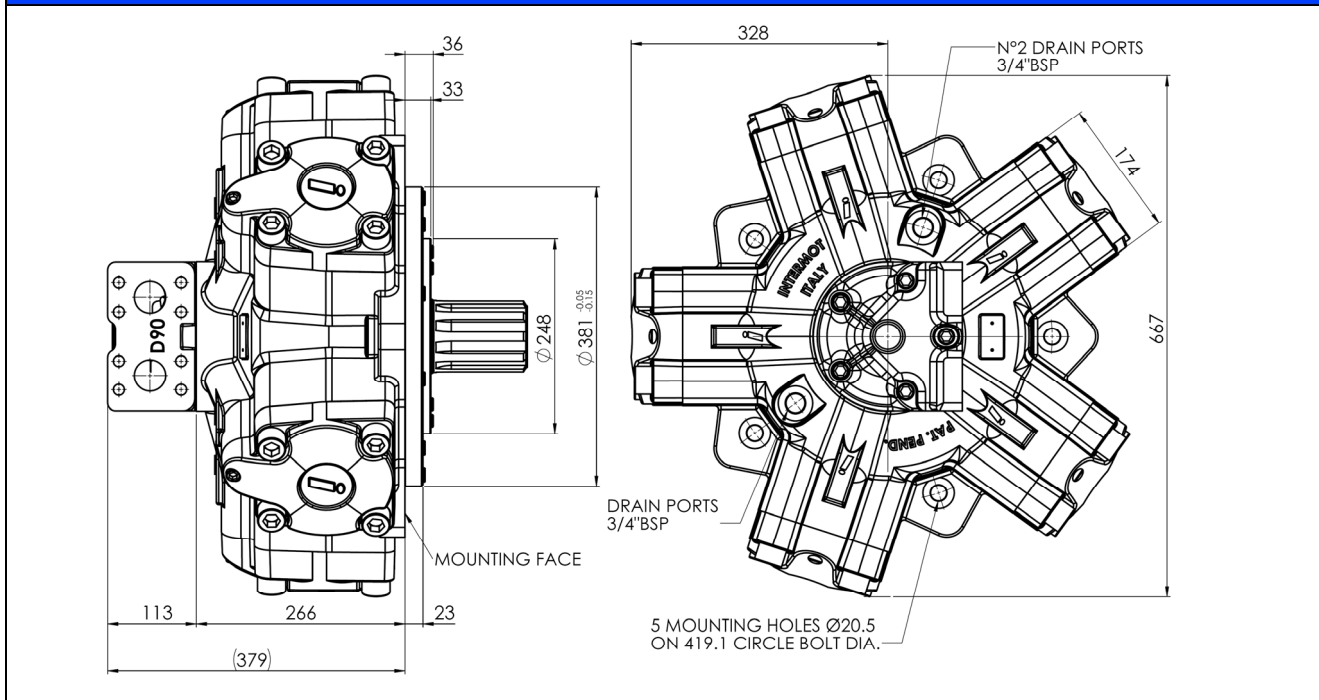

SHAFTS

A0: Standard splined shaft

A1: Splined shaft on request

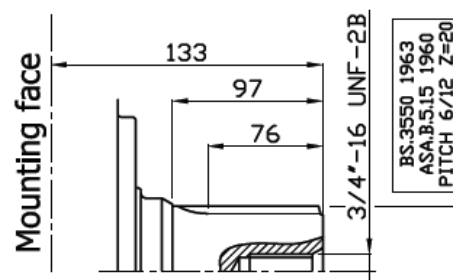
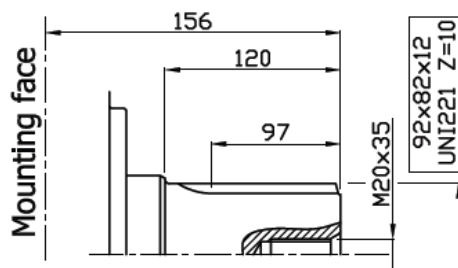

A2: Parallel shaft on request

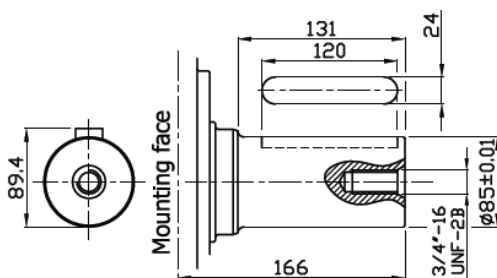

IAM+ H6

Power charts

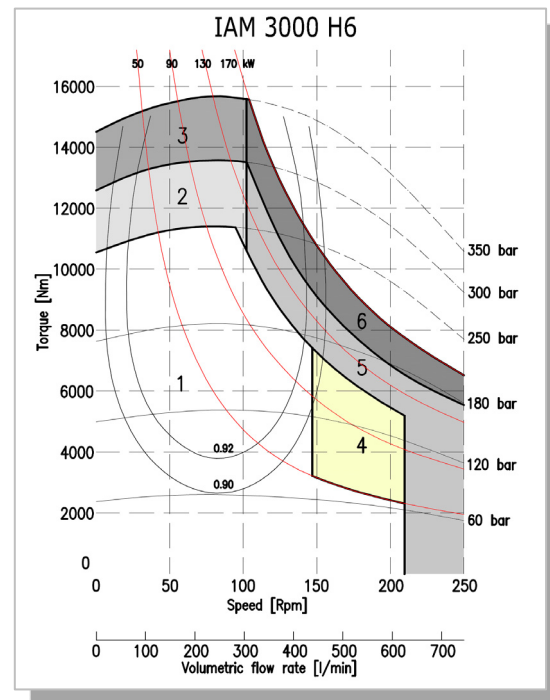
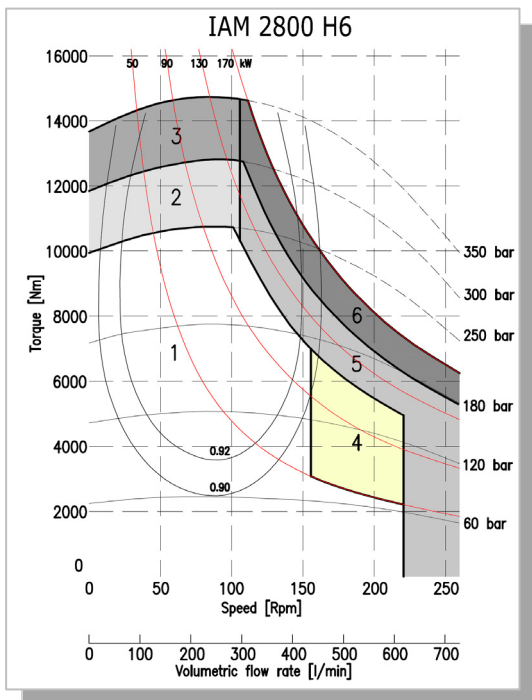
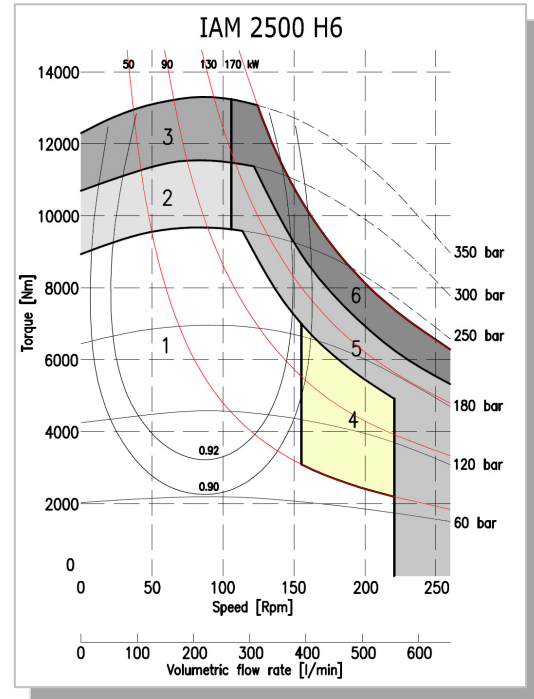
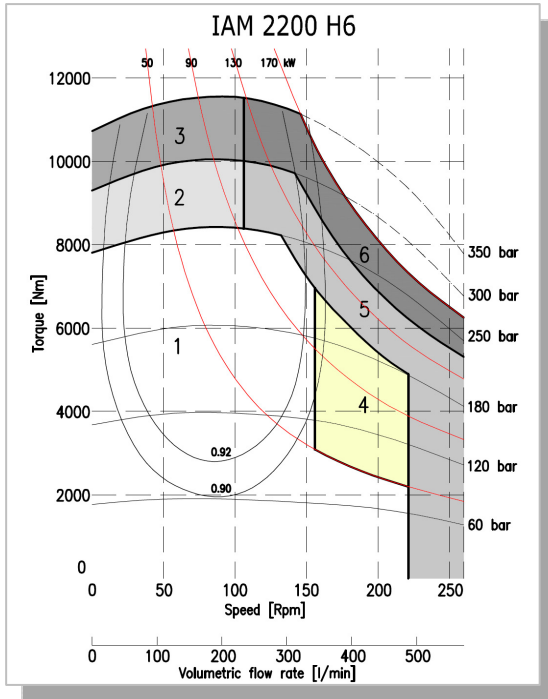

IAM+ H6

Power charts

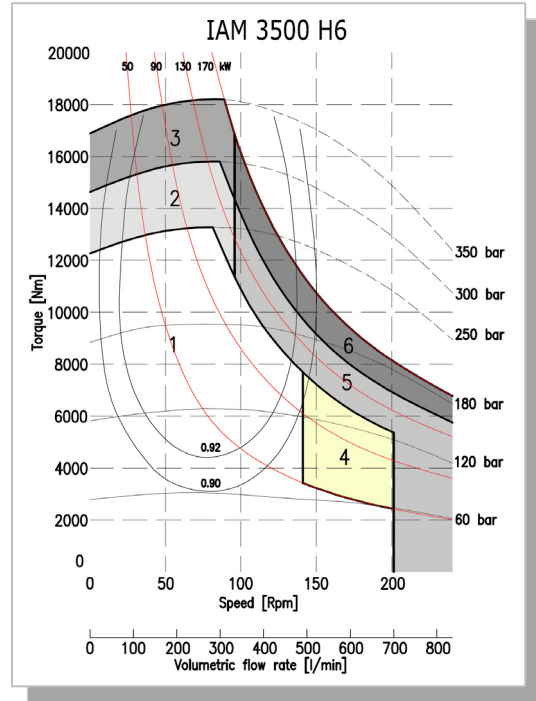
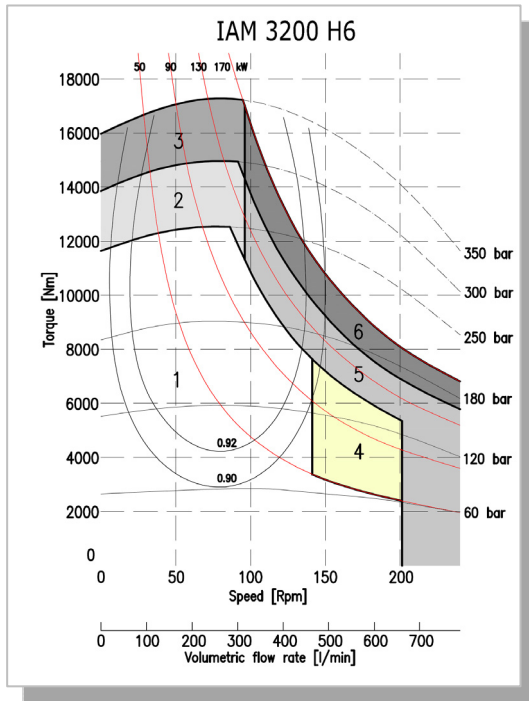

1	Continuous operation	4	Continuous operation with flushing
2	Intermittent operation for period 3-5 minutes every 10-15 minutes	5	Intermittent operation for period 3-5 minutes every 10-15 minutes with flushing
3	Intermittent operation for very short period (3-5 seconds every 10-15 minutes)	6	Intermittent operation for very short period (3-5 seconds every 10-15 minutes) with flushing

IAM+ H6

Side load charts

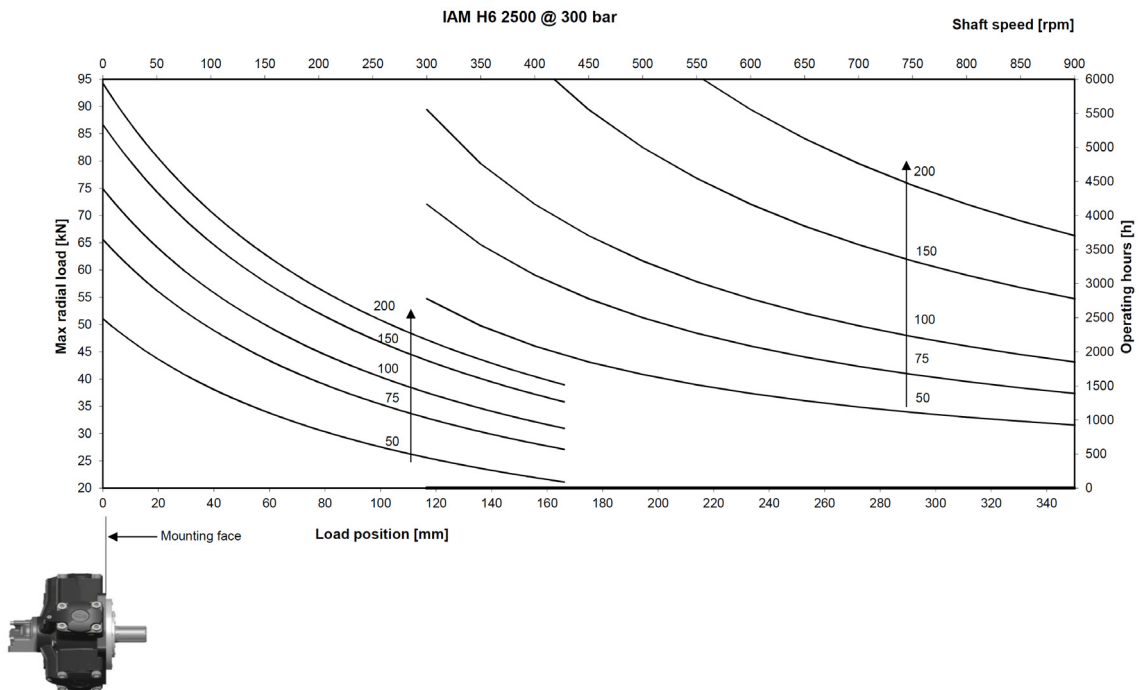
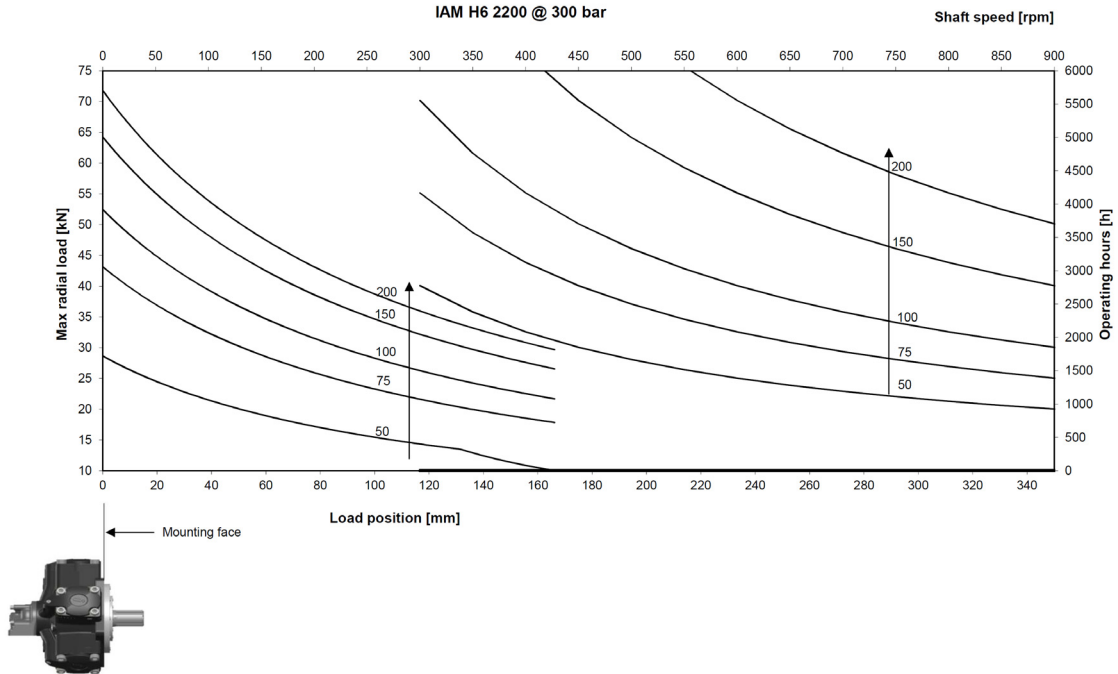

IAM+ H6

Side load charts

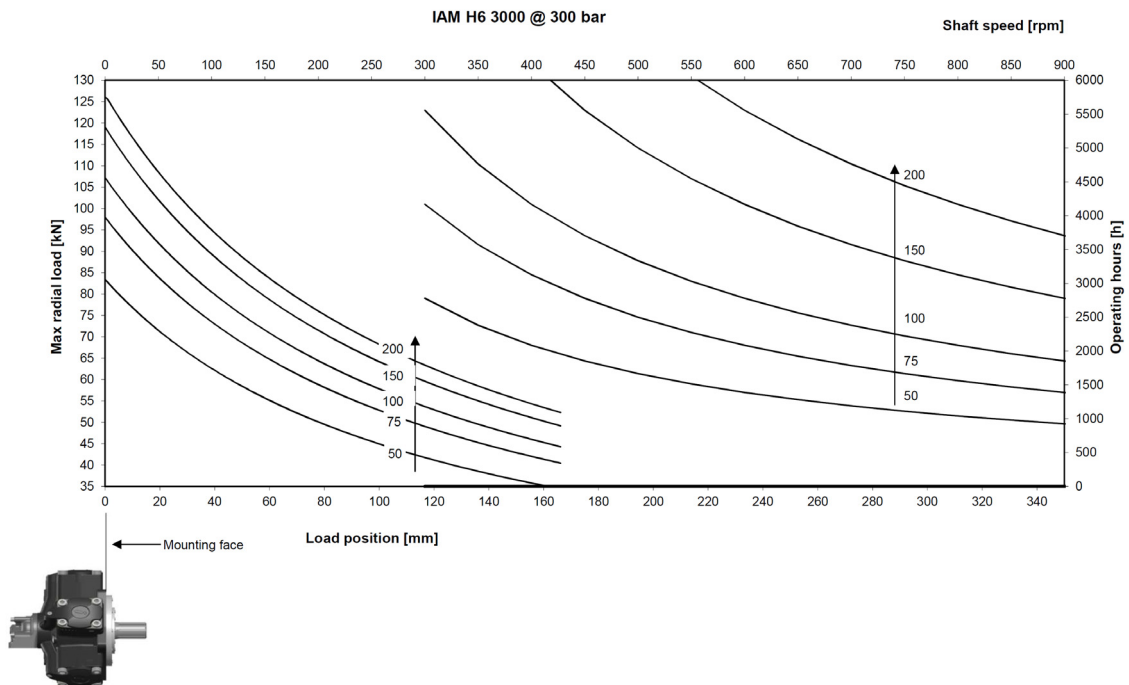
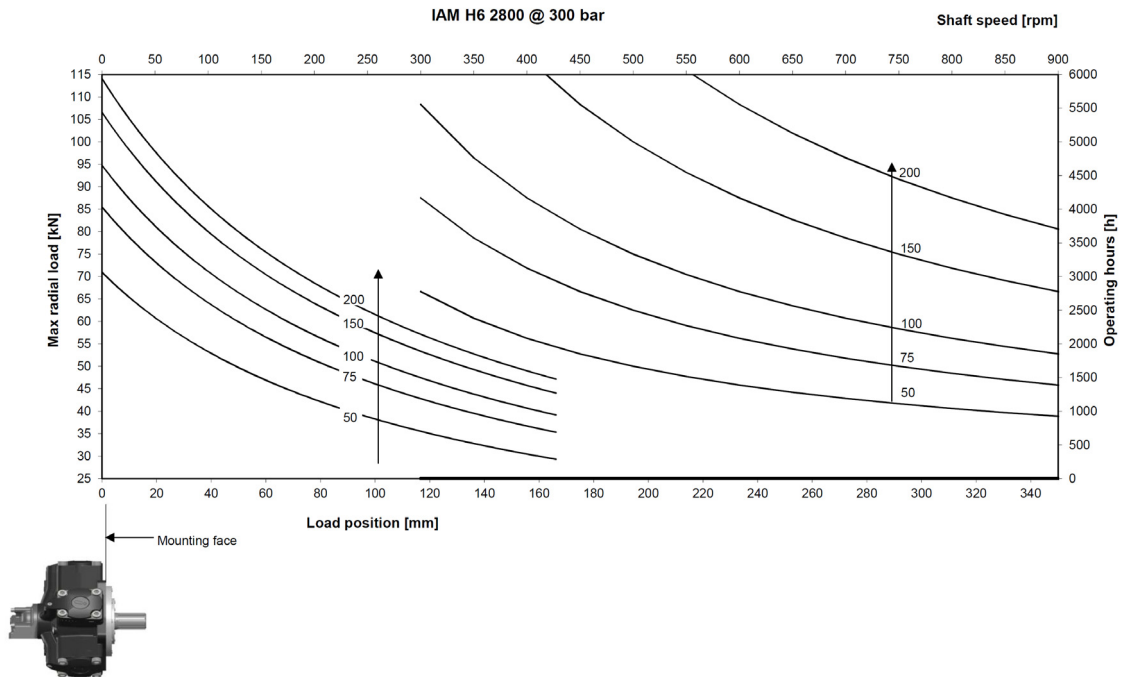

IAM+ H6

Side load charts

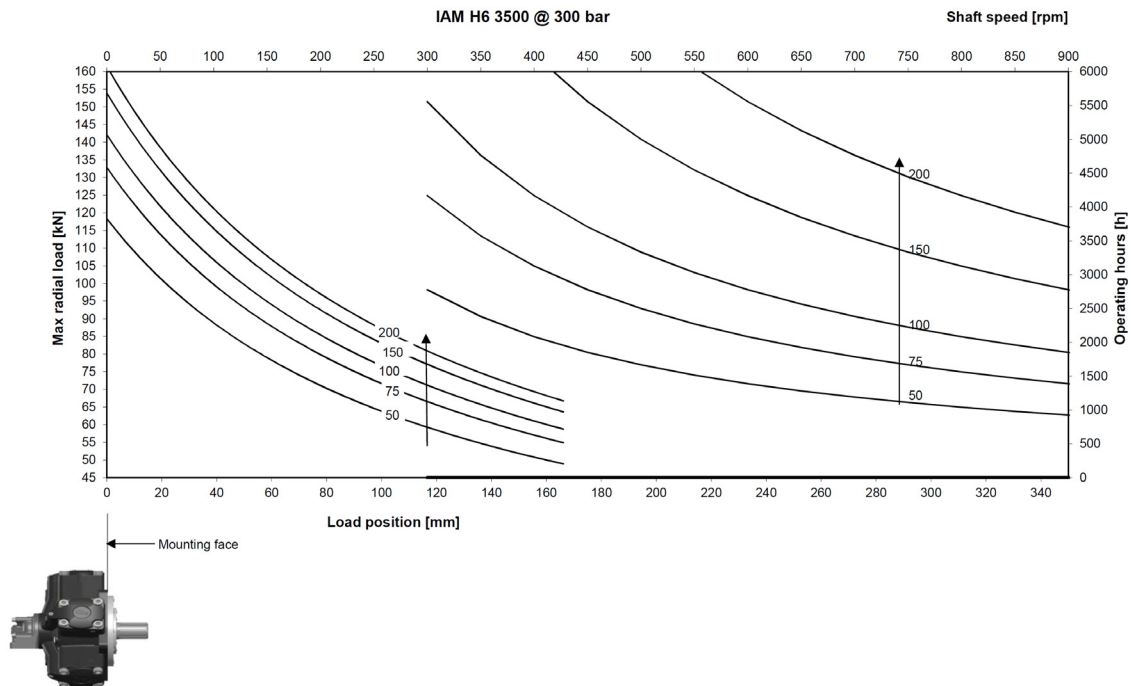
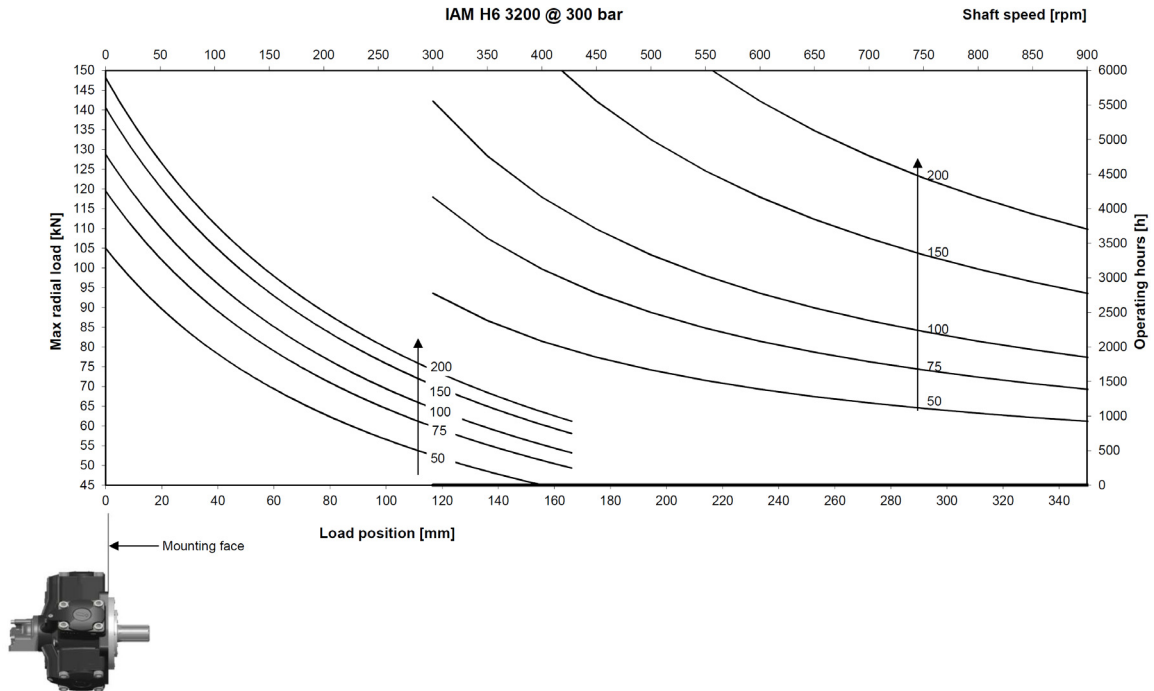

IAM+ H6

Ordering instructions

IAM+	---	H6	A _	D __	--	SB __
Model						
Displacement						
2200 cc/rev						
2500 cc/rev						
3000 cc/rev						
3200 cc/rev						
3500 cc/rev						
Housing						
Shaft						
A0 – Standard splined shaft						
A1 – Splined shaft						
A2 – Parallel keyed shaft						
Distributor						
D90 – SAE 1 ½ “ 6000 psi flange						
Tachometer						
K						
TA						
TB						
EST						
Spline billet						
SB9 – 82 UNI 221						
SB10 – BS 3550 20 T 6/12						

EXAMPLE : IAM+ 3000 H6 A0 D90

IAM+ 3500 H6 A0 D90 EST SB9

***Intermot Hydraulic Motors
IAM+ Series***

H7 Model

IAM+3900 – 4300 – 4600 – 5000 – 5400 H7

INDEX

TECHNICAL DATA	Pag. 68
IAM+ 3900 - 4300 - 4600	
5000 - 5400 H7	Pag. 69
GRAPHIC PERFORMANCES	Pag. 70
ORDERING INSTRUCTIONS	Pag. 75

IAM+ H7

Technical data

MODEL		N° of pistons	Displacement	Specific Torque	Pressure			Speed		Max Power		Dry Mass	Max case pressure	Max back pressure	Temperature range	Minimum speed	Inertia moment of rotating parts
					Max Cont.	Max Int.	Peak	Max Cont.	Peak								
			cm ³ /rev	Nm/bar	bar			rpm		hp	kW	kg	bar	bar	°C	rpm	kg cm ²
IAM+ H7	3900	7	3909	62.2	300	350	400	160	200	290	216	405	6	70	- 30 ÷ +70	0.5	4064
	4300		4345	69.2	300	350	400	150	190	290	216	405					
	4600		4618	73.5	300	350	400	140	190	290	216	405					
	5000		5092	81.0	300	350	400	140	180	290	216	405					
	5400		5387	85.7	300	350	400	130	170	290	216	405					

IAM+ 3900 – 4300 – 4600 – 5000 – 5400 H7

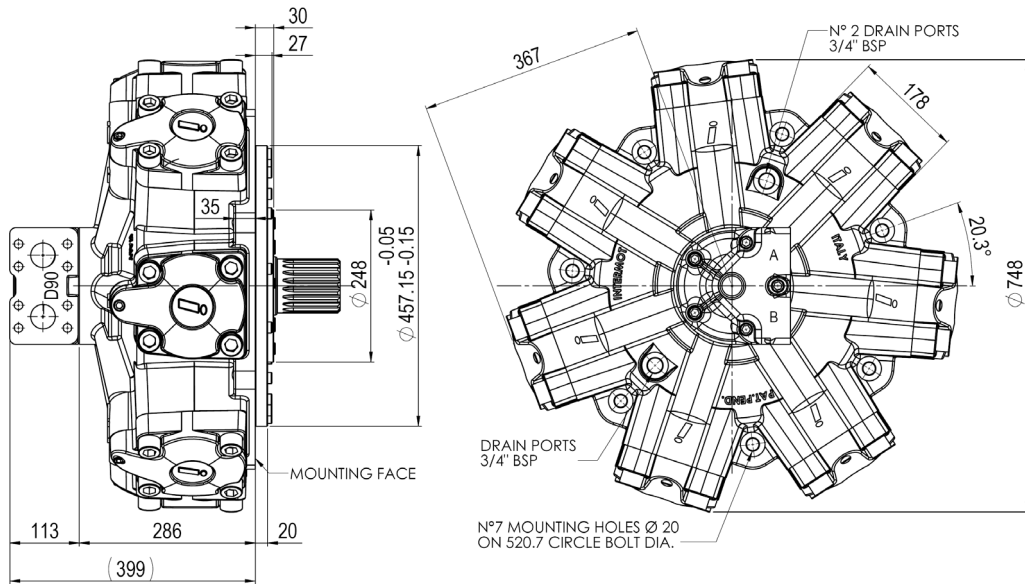

SHAFTS

A1: Standard splined shaft

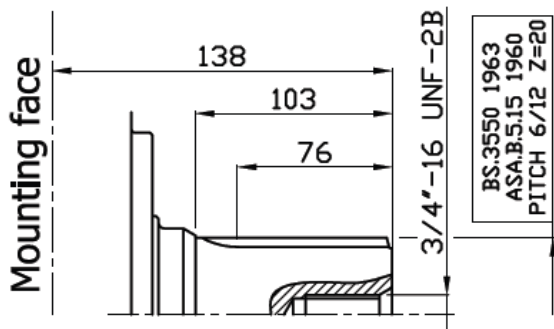

A2: Parallel shaft on request

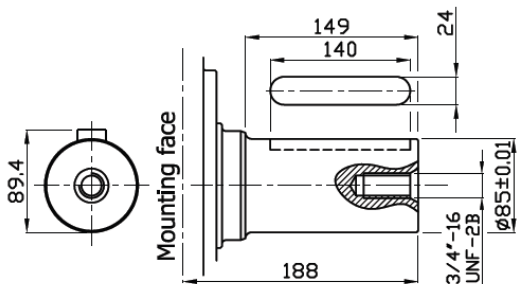

A4: Taper shaft on request

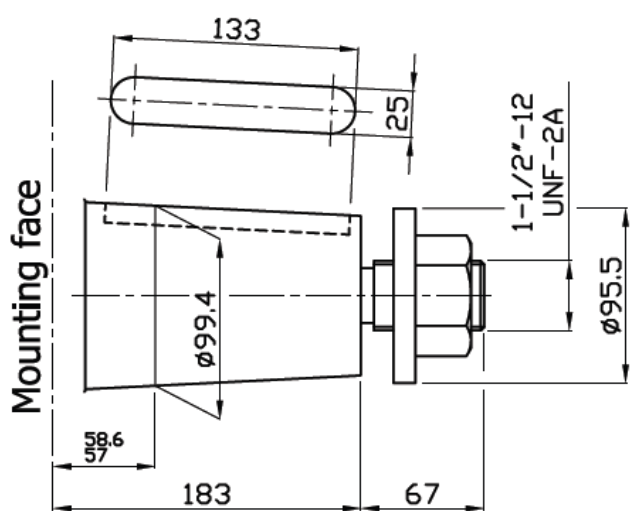

IAM+ H7

Power charts

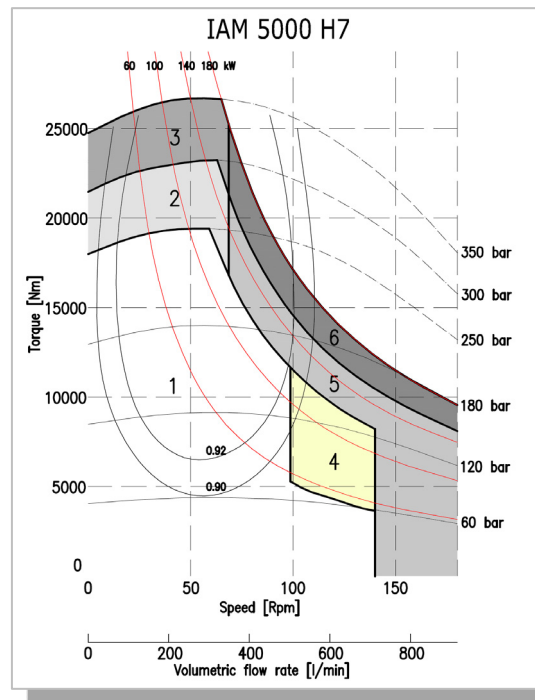
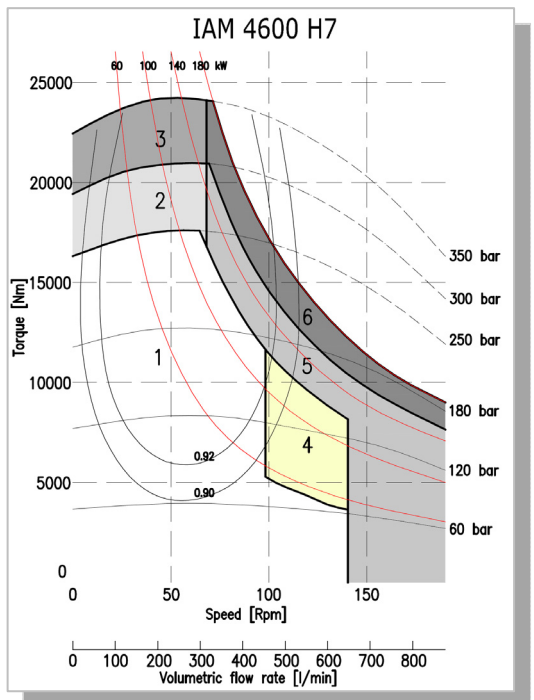
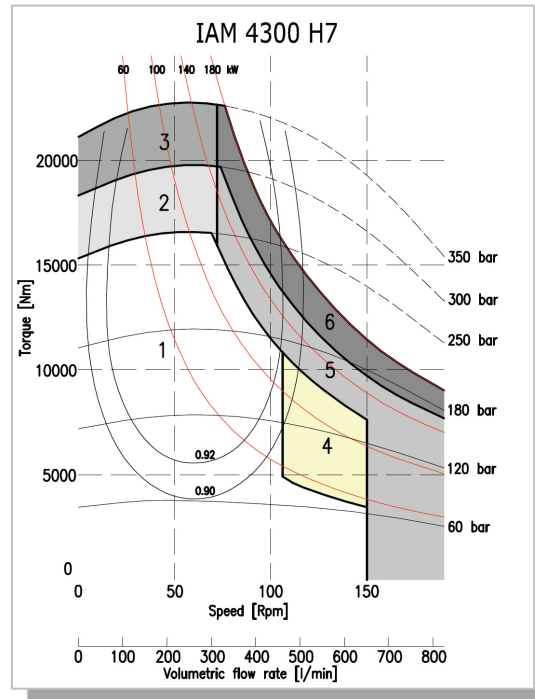
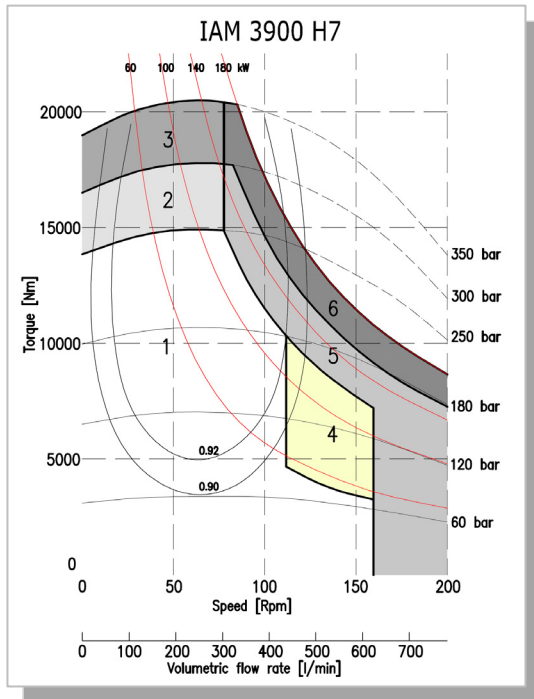

The data specified into this catalogue are for product description purpose only and must not be interpreted as warranted characteristic in legal sense. Intermot reserves the right to implement modification without notice. 70

IAM+ H7

Power charts

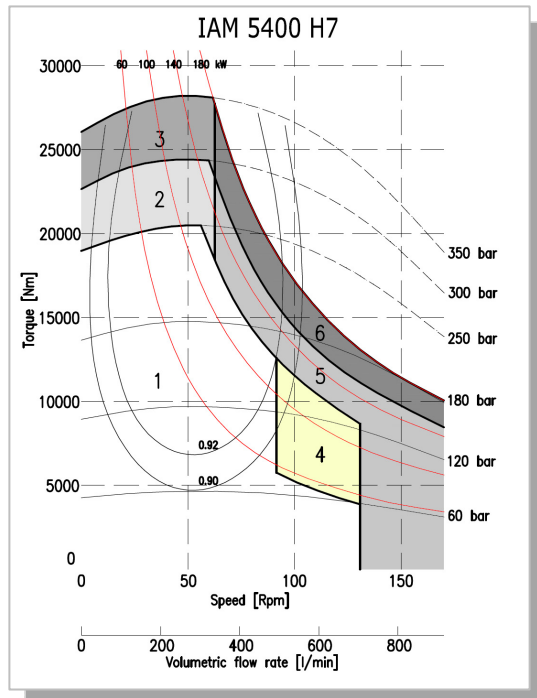

1	Continuous operation
2	Intermittent operation for period 3-5 minutes every 10-15 minutes
3	Intermittent operation for very short period (3-5 seconds every 10-15 minutes)
4	Continuous operation with flushing
5	Intermittent operation for period 3-5 minutes every 10-15 minutes with flushing
6	Intermittent operation for very short period (3-5 seconds every 10-15 minutes) with flushing

IAM+ H7

Side load charts

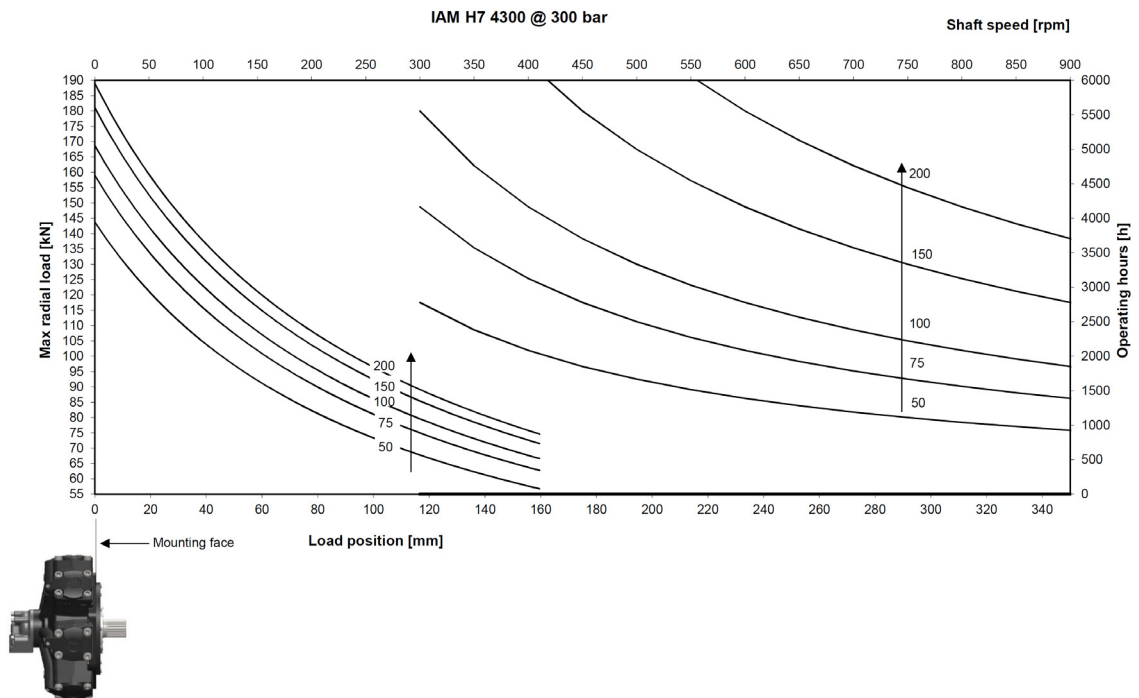
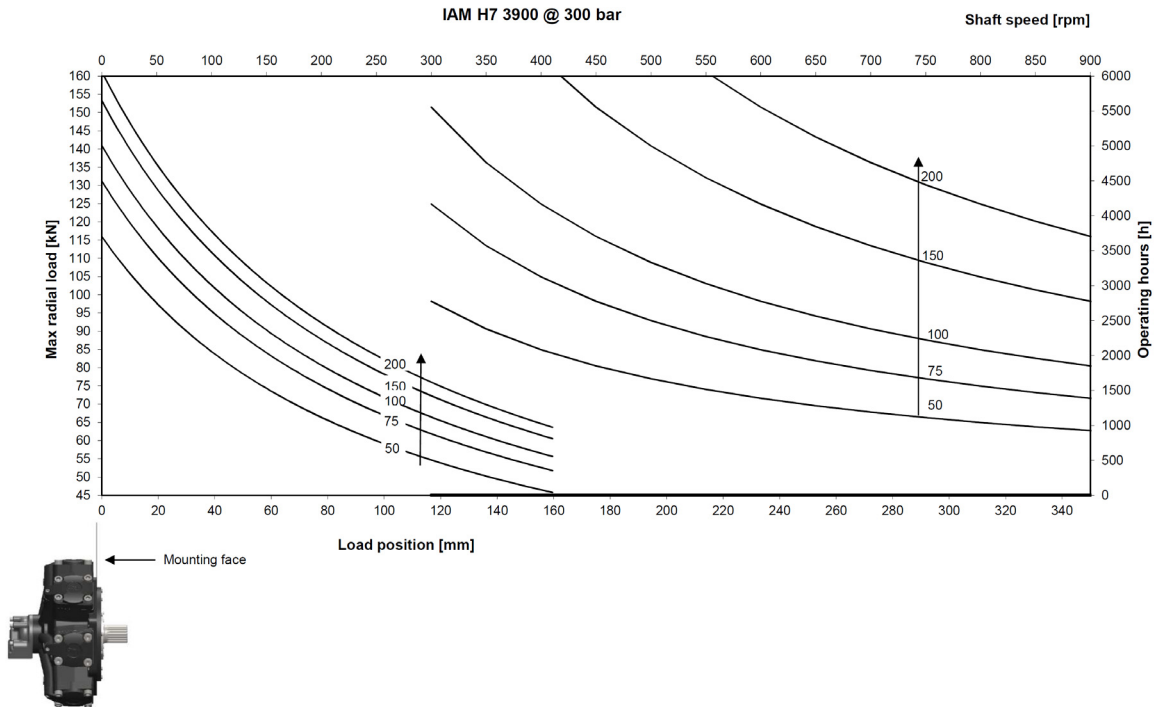

The data specified into this catalogue are for product description purpose only and must not be interpreted as warranted characteristic in legal sense. Intermot reserves the right to implement modification without notice. 72

IAM+ H7

Side load charts

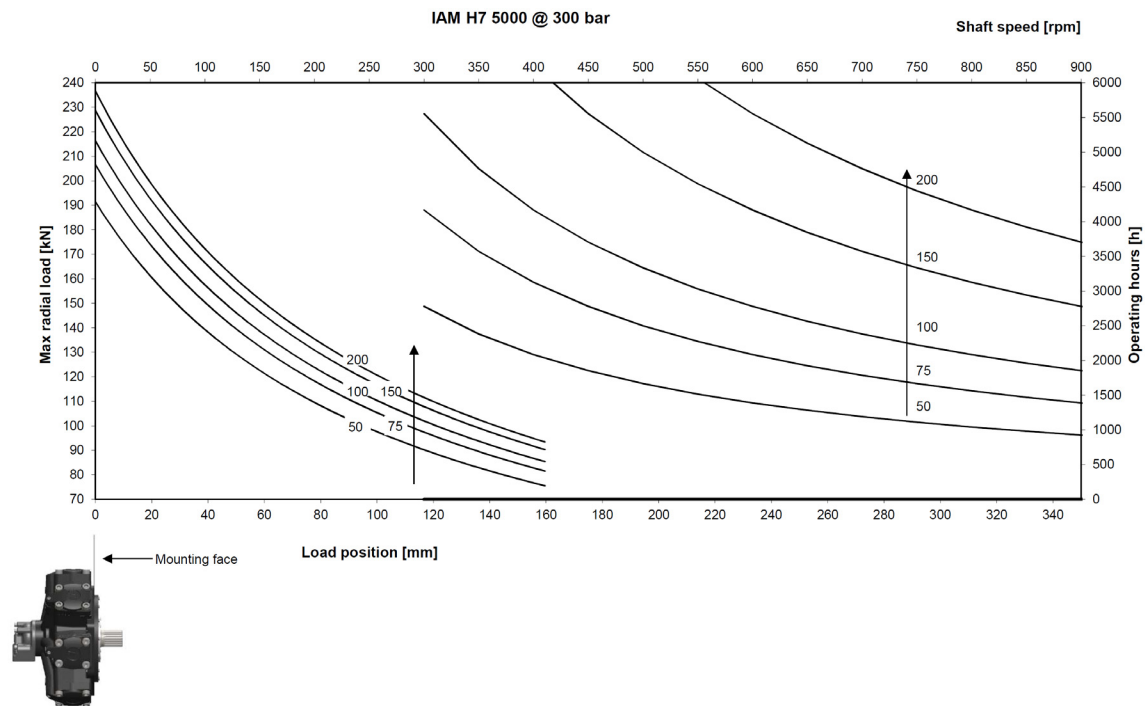
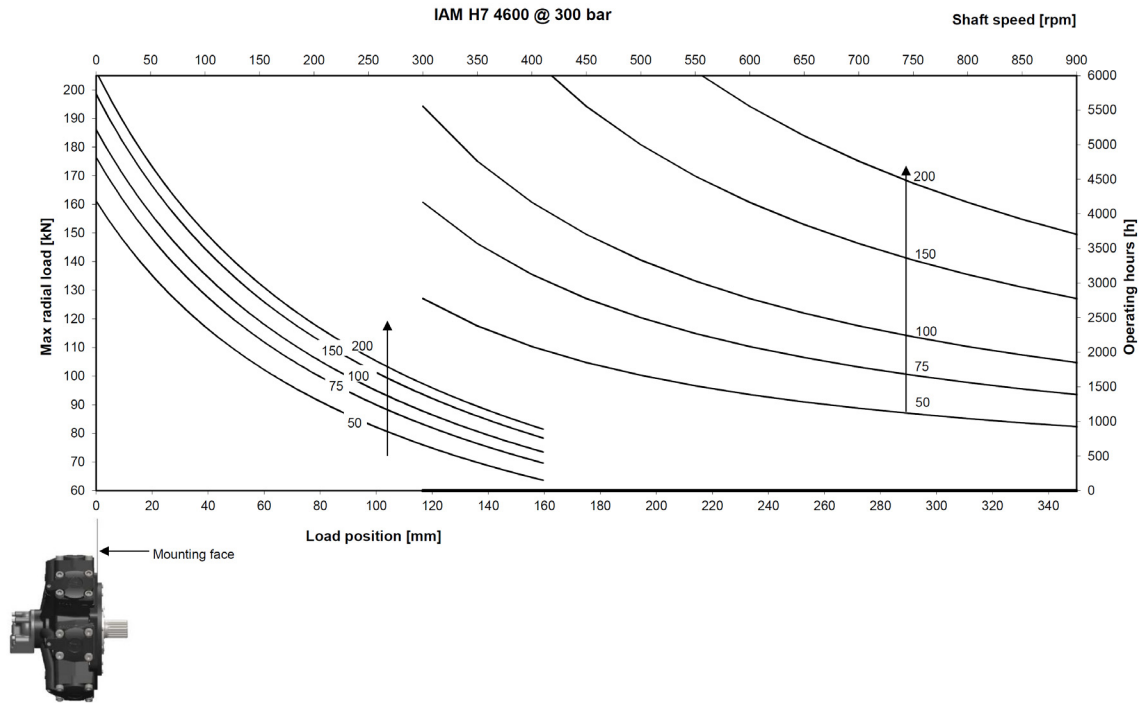

The data specified into this catalogue are for product description purpose only and must not be interpreted as warranted characteristic in legal sense. Intermot reserves the right to implement modification without notice. 73

IAM+ H7

Side load charts

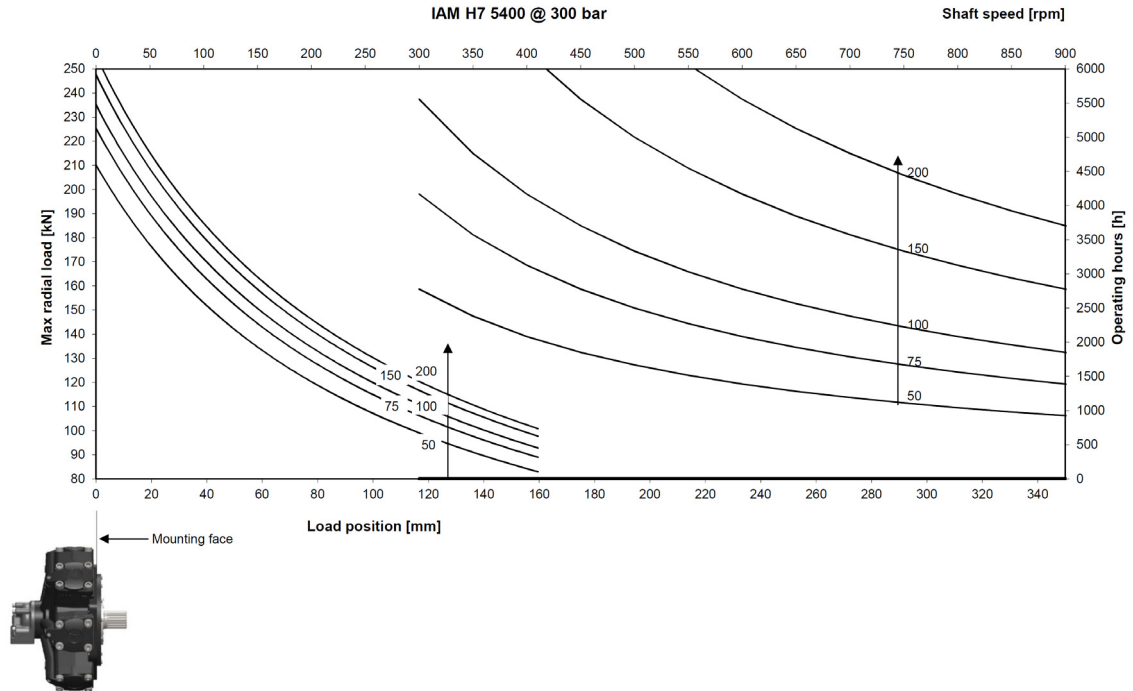

The data specified into this catalogue are for product description purpose only and must not be interpreted as warranted characteristic in legal sense. Intermot reserves the right to implement modification without notice. **74**

IAM+ H7

Ordering instructions

IAM+	---	H7	A _	D _	--	SB _
Model						
Displacement						
3900 cc/rev						
4300 cc/rev						
4600 cc/rev						
5000 cc/rev						
5400 cc/rev						
Housing						
Shaft						
A1 – Standard splined shaft						
A2 – Parallel keyed shaft						
A4 – Tapered shaft						
Distributor						
D90 – SAE 1 ½ “ 6000 psi flange						
Tachometer						
K						
TA						
TB						
EST						
						Spline billet
SB10 – BS 3550 20 T 6/12						
SB11 – 102 UNI 222						

EXAMPLE : IAM+ 4300 H7 A1 D90

IAM+ 4600 H7 A1 D90 TB SB10

Flow distributors

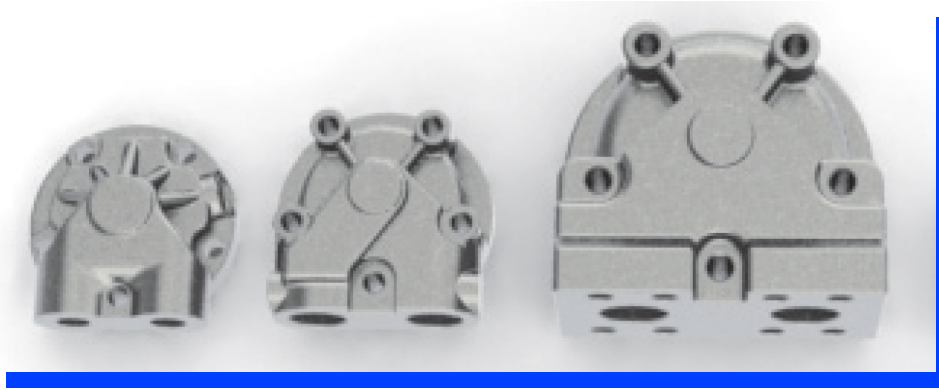

			D31 D310	D40 D47	D90
Speed	[rpm]	cont.	300	1600	700
		max.	500	2400	1200
Pressure	[bar]	cont.	250	250	250
		max.	500	500	500
Flow	[l/min]	cont.	200	200	500
		max.	400	400	1000

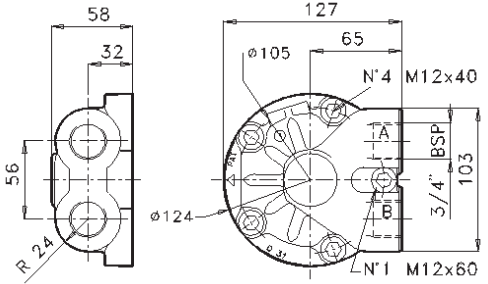
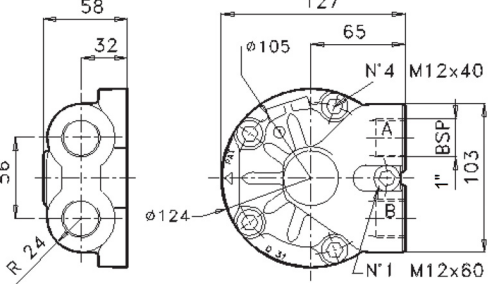
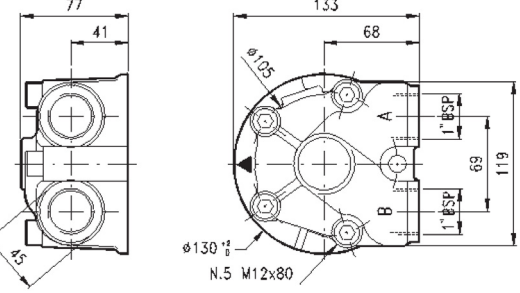
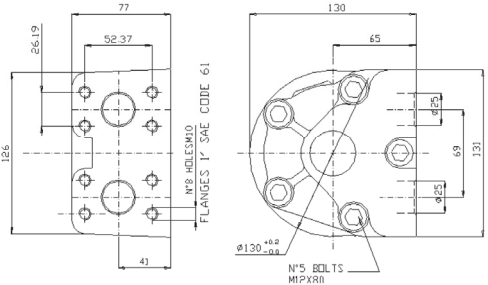
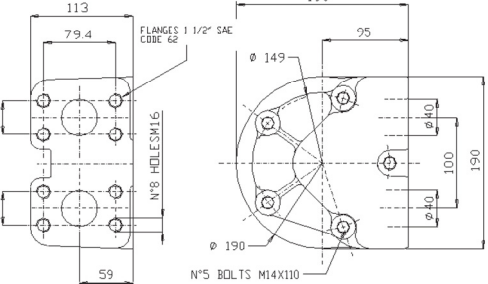
<p style="text-align: center; font-weight: bold; font-size: 24px;">D31</p>	<p>Distributor with 3/4" BSP ports</p> <p><i>Standard for: IAM+ H1 – IAM+ H2</i></p> <p><i>Possible for: IAM+ H3 – IAM+ H4</i></p>	
<p style="text-align: center; font-weight: bold; font-size: 24px;">D310</p>	<p>Distributor with 1" BSP ports</p> <p><i>Possible for: IAM+ H1 – IAM+ H2 – IAM+ H3 – IAM+ H4</i></p>	
<p style="text-align: center; font-weight: bold; font-size: 24px;">D40</p>	<p>Distributor with 1" BSP ports</p> <p><i>Standard for: IAM+ H3 – IAM+ H4</i></p> <p><i>Possible for: IAM+ H1 – IAM+ H2</i></p>	
<p style="text-align: center; font-weight: bold; font-size: 24px;">D47</p>	<p>Distributor with SAE 1" 3000 psi flanges</p> <p><i>Possible for: IAM+ H1 – IAM+ H2 – IAM+ H3 – IAM+ H4</i></p>	
<p style="text-align: center; font-weight: bold; font-size: 24px;">D90</p>	<p>Distributor with SAE 1 1/2" 6000 psi flanges</p> <p><i>Standard for: IAM+ H5 – IAM+ H6 – IAM+ H7</i></p>	

Tachometers

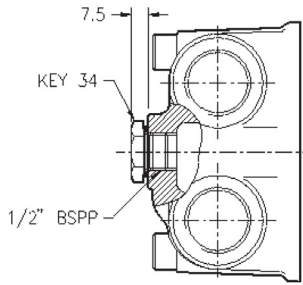
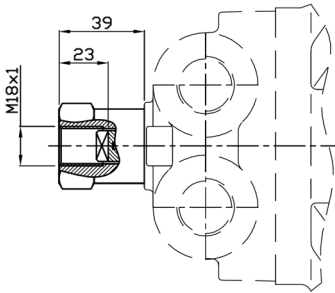
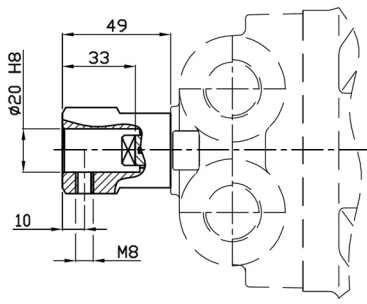
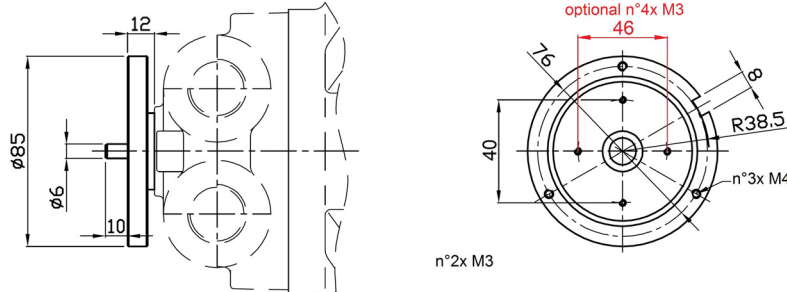
K	Tacho drive plug code K	 <p>7.5 KEY 34 1/2" BSPP</p>
TA	Tacho drive code TA	 <p>39 23 M18x1</p>
TB	Tacho drive code TB	 <p>49 33 10 M8</p>
EST	Tacho drive code EST	 <p>12 10 16 40 46 76 8 38.5 n°2x M3 optional n°4x M3 n°3x M4</p>

Spline billets

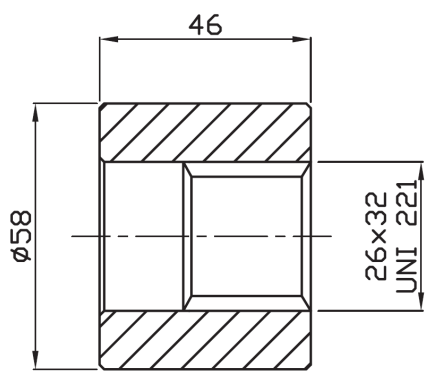
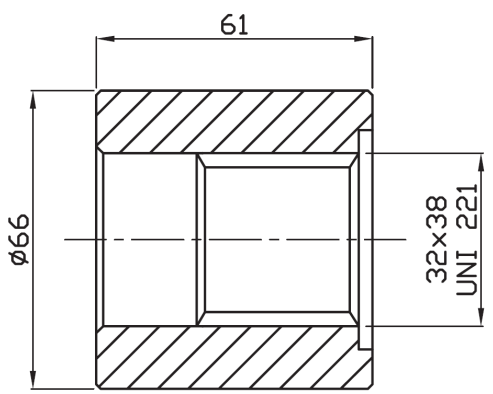
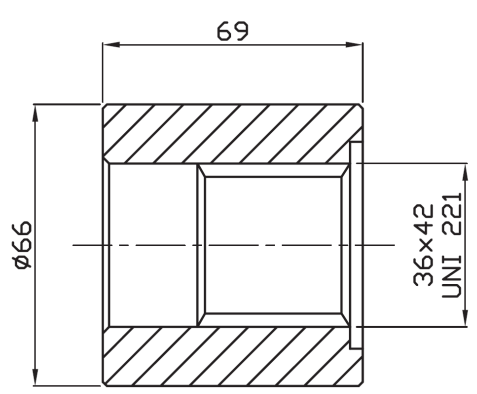
SB1	<p>Only for:</p> <p><i>IAM+ H1 100 – 150 – 175 A0</i></p> <p><i>IAM+ H1 100 – 150 – 175 A1</i></p>	
SB2	<p>Only for:</p> <p><i>IAM+ H1 200 – 250 – 300 A0</i></p> <p><i>IAM+ H2 200 – 250 – 300 – 350 A0</i></p>	
SB3	<p>Only for:</p> <p><i>IAM+ H2 400 – 500 – 600 A0</i></p> <p><i>IAM+ H3 400 – 500 – 600 – 700 A0</i></p>	

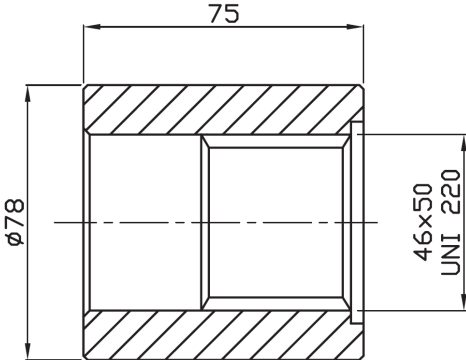
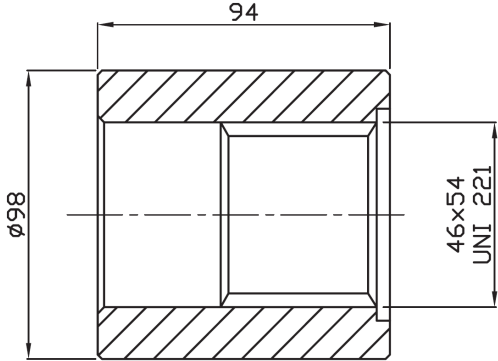
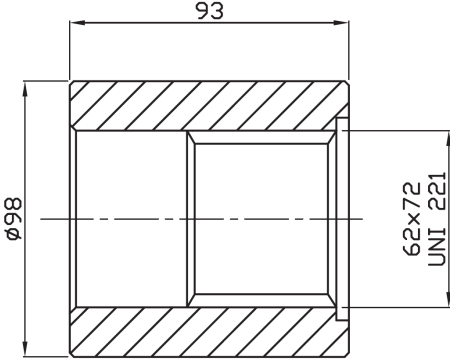
SB4	<p>Only for:</p> <p><i>IAM+ H3 800 A0</i></p> <p><i>IAM+ H4 800 – 900 – 1000 – 1100 – 1400 A0</i></p>	
SB5	<p>Only for:</p> <p><i>IAM+ H4 800 – 900 – 1000 – 1100 – 1400 A1</i></p>	
SB6	<p>Only for:</p> <p><i>IAM+ H5 1200 – 1400 – 1600 – 1800 – 2000 – 2200 A0</i></p>	

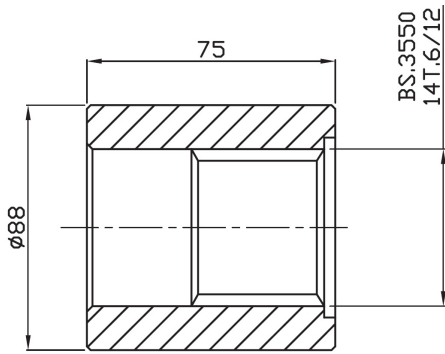
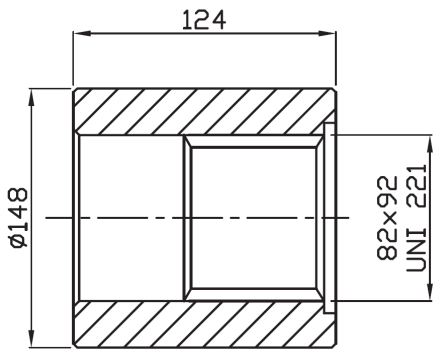
SB7	<p>Only for:</p> <p><i>IAM+ H5 1200 – 1400 – 1600 – 1800 – 2000 – 2200 A1</i></p>	
SB9	<p>Only for:</p> <p><i>IAM+ H6 2200 – 2500 – 2800 – 3000 – 3200 – 3500 A0</i></p>	
SB10	<p>Only for:</p> <p><i>IAM+ H6 2200 – 2500 – 2800 – 3000 – 3200 – 3500 A1</i></p> <p><i>IAM+ H7 3900 – 4300 – 4600 – 5000 – 5400 A1</i></p>	